

# A-1034

# Quick Start Guide

## LITHIUM ELECTRIC PALLET JACK

Rated Load Capacity: 3,300lbs

Fork Size: 48x27 inch

Scan the QR Code for more information.



Thank you for choosing our full electric pallet jack.

For safe and correct use, please read this manual carefully and follow all instructions, precautions, and prohibitions. Keep this manual for future reference. Product specifications may change without notice. If there is any difference between this manual and the actual product, the product shall take precedence.

# TABLE OF CONTENTS

## INTRODUCTION

1. Warning
2. Parts Introduction
3. Installation Instruction
4. Inspection & Maintenance
5. Customer Support

# 1. WARNING

## ● Operating Environment

1. Operate this product only on hard, level surfaces.
2. Do not operate if the ambient temperature is above 104°F (40°C) or below 14°F (-10°C).
3. Do not operate in flammable, explosive, or corrosive environments.
4. Do not operate in cold storage or humid environments.

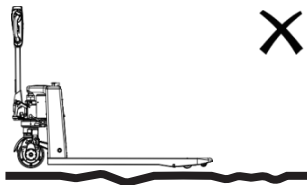
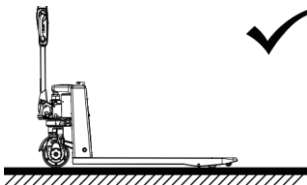

## ● Operational Guidelines

### 1. Starting the Product Safely

- Wear safety shoes and ensure familiarity with all controls before starting the product.
- Sound the horn to alert nearby personnel.

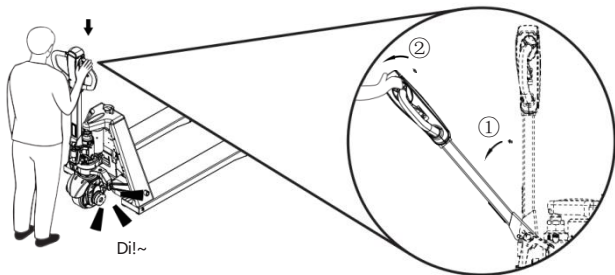

## 2. Ramp Operation

- When ascending with a load, keep the forks facing uphill.
- When descending, operate the product in reverse to keep the forks facing uphill.

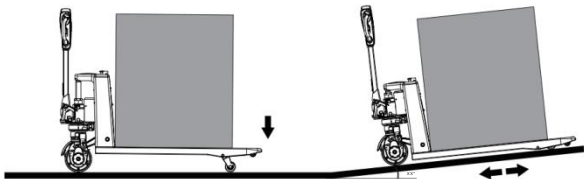

## 3. Personnel Safety

- Do not carry passengers.
- Keep all body parts, especially hands and feet, clear of the forks and moving parts.

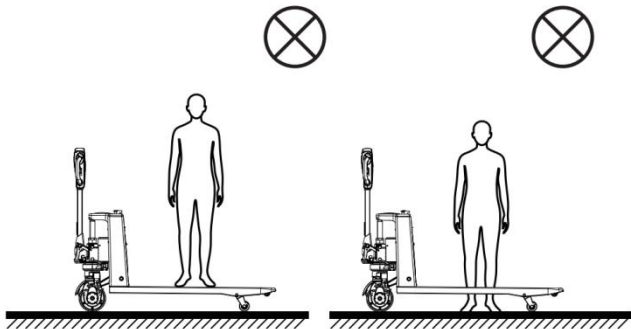

#### 4. Load Limits

- Do not exceed the rated load capacity.
- Place loads securely in the center of the forks.
- Do not transport loose or unstable items.

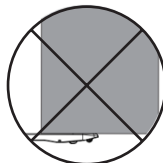
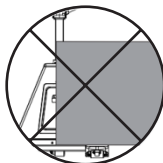
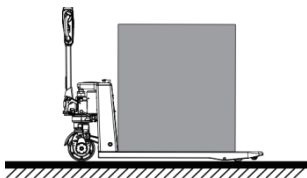

#### ● Traveling and Lifting Guidelines

##### 1. Starting and Traveling

- Sound the horn to alert nearby personnel before starting.
- Slowly rotate the forward/reverse rocker on the control handle to control the product's forward or backward speed and direction.

##### 2. Braking

- Release the forward/reverse rocker. The product will automatically apply regenerative braking.
- Move the control handle to the vertical or horizontal position. The product will automatically engage electromagnetic braking.
- Press the emergency stop switch. The product will stop immediately.

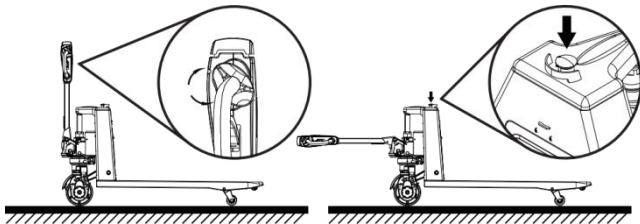

### 3. Lifting and Lowering

- Press the raise button on the control handle to lift the forks.
- Lift the lowering lever on the control handle to lower the forks smoothly.

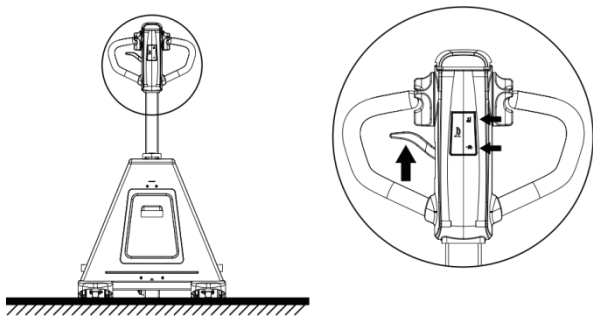

### 4. Ramp Operation

- When ascending with a load, keep the forks facing uphill.
- When descending, operate the product in reverse, keep the forks facing uphill, and control speed carefully.

### 5. Charging

- Lower the forks and turn off the power.
- Charge the product in a well-ventilated area using the designated charger.
- The product is equipped with a lithium battery and can be charged as needed.
- If the product is unused for more than one month, charge the battery monthly to maintain its performance.

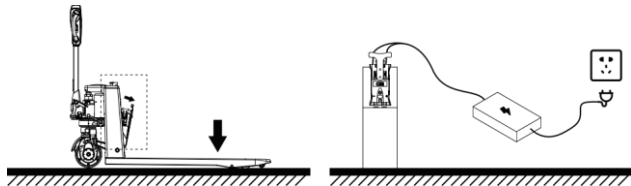

## 2. Hydraulic Pump Station

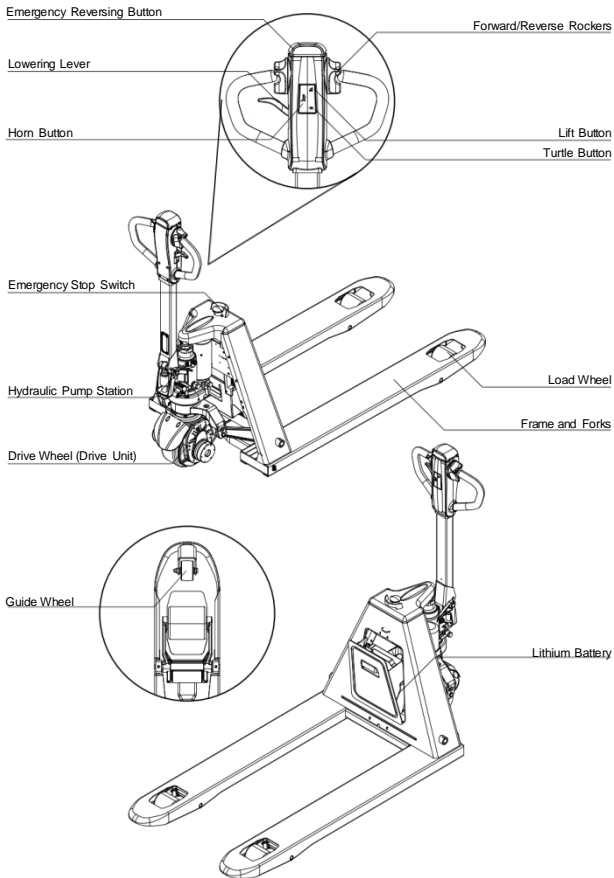

### 3. Installation Instruction

- The product is mostly pre-assembled at the factory.  
Before use, only the control handle needs to be installed.

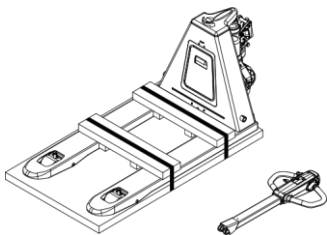

- ① Carefully unpack and check accessories (Charger, Manual, Handle)

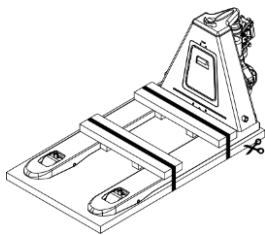

- ② Remove all straps and the protective foam/wood from the handle

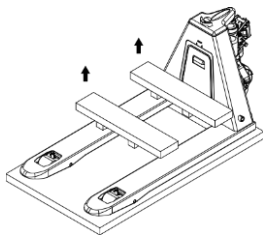

- ③ Remove all straps and the protective foam/wood from the handle.

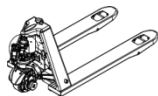
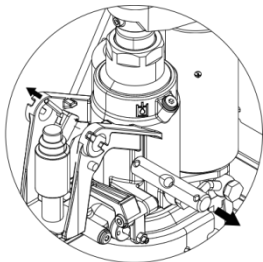

- ④ Remove the large Axle Pin

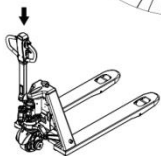
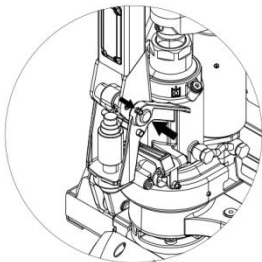

- ⑤ Align the handle with the mounting hole and insert the Axle Pin

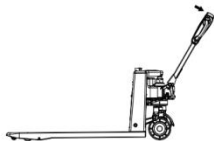
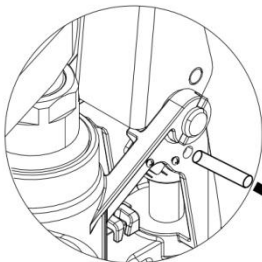

- ⑥ Press the handle down to release and remove the Spring Locking Pin

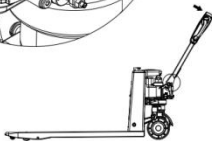
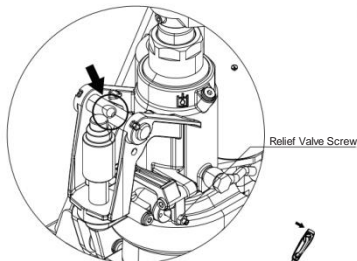

- ⑦ Feed the chain through the pin hole.

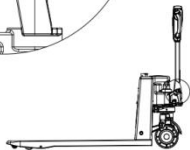

- ⑧ Hook the chain onto the lever plate and secure the nut

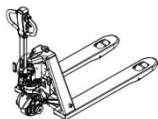
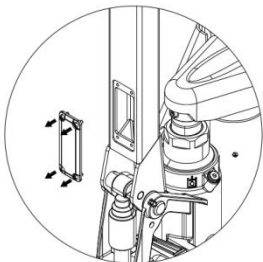

⑨ Open the handle cover

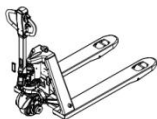
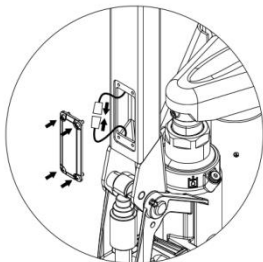

⑩ Connect the wires, and reinstall the cover.

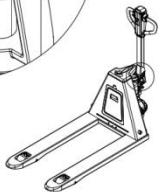
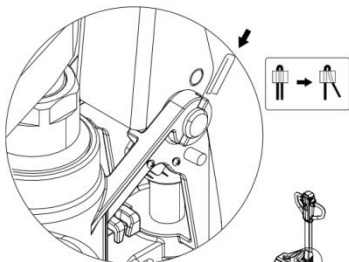

⑪ Connect the wires, and reinstall the cover.



⑫ Open the battery compartment and connect the battery. Pull the Emergency Stop to power on.

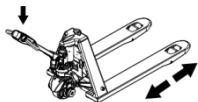
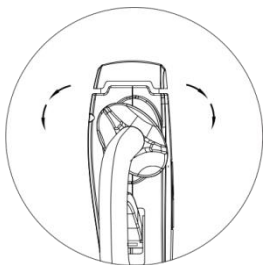

- 13 Press the handle to the drive position and test all functions (Throttle, Lift, Horn, Turtle Speed).

Lowering Lever

Lift Button

Turtle Button

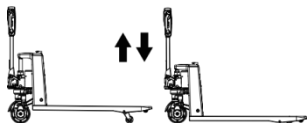

## 4. Inspection & Maintenance

Conducting a thorough inspection of the product can help prevent malfunctions and ensure it achieves its expected service life. Maintenance hours are based on 8 hours of operation per day, 200 hours per month. For safe operation, the product should be inspected and maintained according to the maintenance schedule.

### ● 200-Hour Inspection and Maintenance

No.	Component	Inspection or Service
1	Overall Condition	Check for visible damage or oil leaks (hydraulic oil, gear oil).
2	Fastener	Check all bolts, especially on wheels and handle, for looseness
3	Electrical System	Check the battery charge level and ensure the horn and emergency stop switch function properly.
4	Braking System	Check that the brake works effectively when the handle is in vertical and horizontal positions.
5	Wheel	Inspect drive wheels and load wheels for serious wear or entanglement with debris.
6	Horn	Check sound function.
7	Hydraulic Oil	Check oil level. Replace after the first 500 hours, then every 1,000 hours thereafter.
8	Control Handle	Check for binding or looseness in steering.
9	Frame & Fastener	Inspect for cracks; check if all fasteners are secure.
10	Connecting Rod Wheel Carrier	Inspect for cracks, bends, or deformation.
11	Jack Pump & Oil Hose	Check for leakage.
12	Power Plug	Ensure proper operation.
13	Emergency Stop Switch	Ensure proper operation.
14	Brake	Clean dirt and dust from brake pads; check wear condition.
15	Drive Wheel	Check for wear; replace if function is impaired.
16	Fork Wheel, Guide Wheel & Bearing	Check for wear; replace if function is impaired.
17	Lubrication	Apply grease to all bearings and pivot points.

### ● Maintenance Intervals for Consumables and Components

Component	Inspection or Service	Interval (hours)
Fork Wheel Bearing	Replace	1,200
Fork Wheel	Replace	1,200
Seal	Replace	1,200
Gearbox	Change lubricant	1,000
Hydraulic Oil	Replace	1,000
Drive Wheel Tire	Replace	2,000
Drive Motor	Inspect brushes and bearings	1,000
Oil Pump Motor	Inspect brushes and bearings	1,000

## 5. Customer Support

- Warranty Period

1. **New Product (Complete Unit):**

1-year warranty from the date of receipt.

2. **Spare Parts:**

3-month warranty from the date of receipt.

3. **Battery:**

6-month warranty from the date of receipt.

4. **Used Product (Complete Unit):**

3-month warranty from the date of receipt.

- Warranty Coverage

Complete product and its accessories.

- Non-Warranty Items

1. Wearable parts, such as wheels under normal use and fuses.

2. Damage caused by improper or incorrect operation.

1. **Apollo Sales-after: [service@apolloliftus.com](mailto:service@apolloliftus.com)**

Apollo Customer Service: 224-353-6408

2. **XILIN Sales-after: [support@xilin.com](mailto:support@xilin.com)**

XILIN Customer Service Phone: 224-353-6341

3. **Tory Carrier Sales-after: [service@torycarrier.com](mailto:service@torycarrier.com)**

Tory Carrier Customer Service Phone: 224-353-6781

4. **Aequanta Sales-after: [service@aequanta.com](mailto:service@aequanta.com)**

Aequanta Customer Service Phone: 224-353-6408 (暂时同Apollo)

Working Hours: 9:00 AM to 5:30 PM CDT (夏季) /CST (冬季)