

CBD15W-IILi/CBD20W-IILi

Electric Pallet Truck

- Operation Manual
- Parts Catalogue

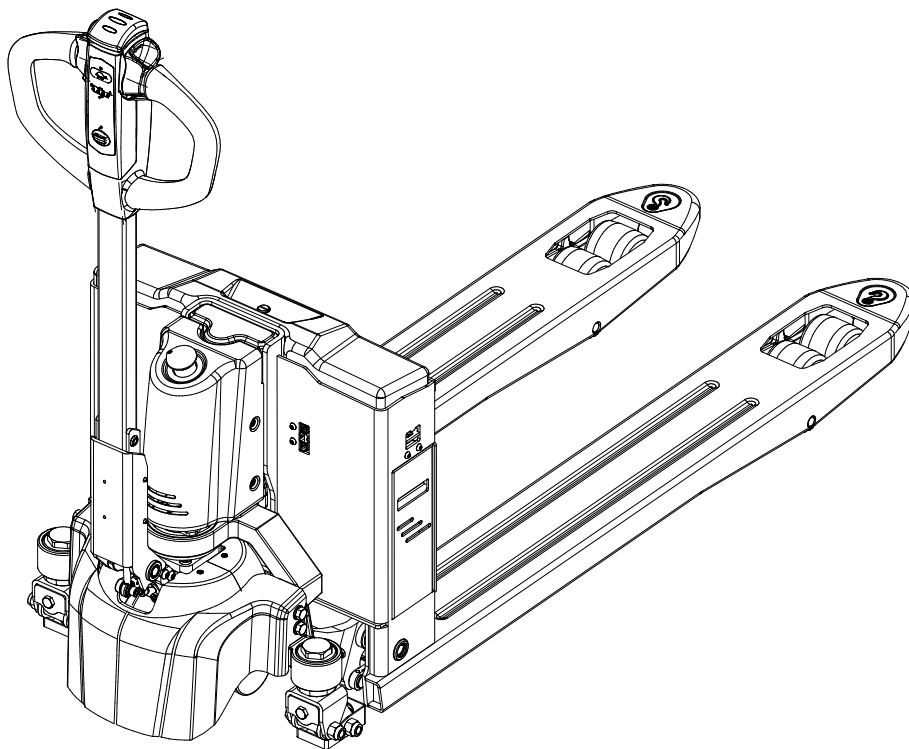

**Thank you for choosing CBD15W-IILi/CBD20W-IILi
electric pallet truck!**

They are designed to improve material handling productivity.

- **Please read the manual carefully before starting the truck.**
- **This operation manual is general, and the right to make any technical modifications to the tractors is reserved. Contents provided in this manual for reference only and if wrong in real, prevail in kind.**

Contents

1. Safety regulations	1
2. Allowed environment for using	2
3. Technical parameters	3
4. Assembly before operation	5
5. Operation	6
6. Use, maintenance and charging of storage battery	11
7. Maintenance	12
8. Truck hoisting	13
9. Trouble shooting	14
10. Waste treatment	14
11. Accessories and spare parts	14
12. Electrical schematic diagram and fault code	15
13. Packing list	23

1. Safety regulations



Safety shoes are always required to handle the pallet truck.



Safety glasses are recommended to avoid personal accidents while assembling or disassembling the pallet truck.



CAUTION

When the truck is damaged or has safety problems, stop using it immediately.



CAUTION

The pallet truck is designed for hard and flat floor only.

It's forbidden to use the truck when :

- the air contains dust or flammable and explosive gases that can cause fire or explosion.
- in freezer or some low temperature, salty or other corrosive environment.
- Rainy outdoor.
- Operate on gravel or grassland.
- the gradient of the ground is greater than the gradient of product design.



CAUTION

- Careful judgment and responsible attitude should be taken in the operation of pallet trucks.
- The pallet truck is not able to be operated with oily hands or shoes
- Operators shall not wear loose clothes or jewelry



CAUTION

- When operating the pallet truck, it is necessary to ensure that the ground has sufficient load bearing capacity, where the load is the sum of the weight of the pallet truck and the load.
- Special care should be taken if there are prominent objects that can cause personal injury
- Personnel are prohibited around the operating area of the pallet truck, which may cause personal injury, for example, when the goods fall.

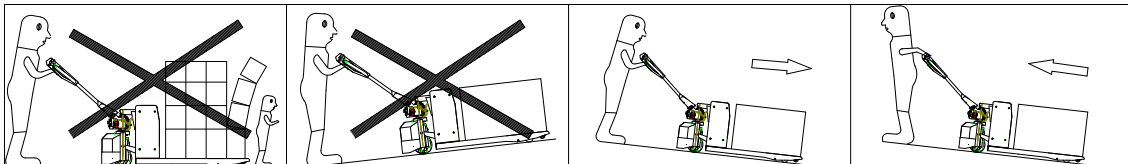

CAUTION

Operators must be very carefully when handling the pallet truck on a slope. See the drawing, the operator should stand ahead of the truck. Operators must be very carefully when handling the pallet truck on a slope. See the drawing, the operator should stand ahead of the

truck. When a truck runs on a ramp, the driving wheel can be quickly turned to the maximum angle to avoid the risk that the truck will continue to slide. This method allows operation only in emergencies.



WARNING!

- Avoid high-speed operation when turning to avoid the danger of overturning.
- The goods should not be too high to block sight.
- Brake gently and carefully to avoid cargo slipping off the pallet and causing material damage.
- The pallet truck is not allowed to turn on the slope.
- Before pushing the pallet into the elevator, the operator must ensure that the elevator can withstand the total load of the pallet and cargo, the total weight of the operator and other personnel on the elevator. Make sure the load goes into the elevator first, then the operator. The elevator should keep empty when the pallet truck with load is about to go in/out of it.



CAUTION!

- The load shall not exceed the rated load of the truck.
- When stacking goods, the goods should not be too high to avoid the danger of falling down or overturning the pallet truck during handling.
- It's forbidden to ride people with the pallet truck.
- Keep clear of the pallet truck's working area, avoiding personal injuries due to sudden accidents happened over its working.
- Standing and sitting on the pallet truck is strictly forbidden.

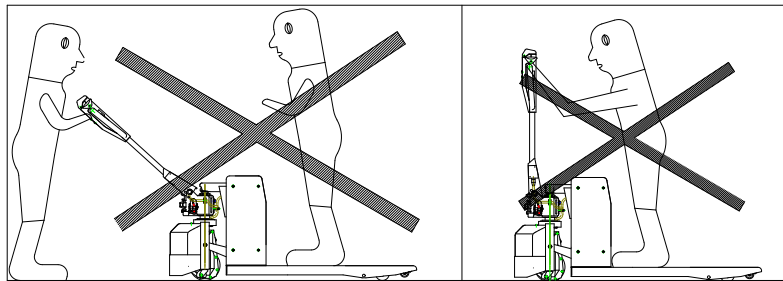

CAUTION!

- Keep the fork at the lowest position while it's parked.
- Don't leave the truck on a slope.
- Don't leave the truck at the emergency access.
- Don't leave the pallet truck to block the traffic or affect work.
- Don't use the pallet truck in rain.
- Turn off the power when the pallet truck is unattended.

2. Allowed environment for using

This truck is designed to work only on hard and flat floor, indoor. It is not allowed to work in an environment beyond the regulations.

- Ambient temperature shall not be higher than +40°C and no lower than -10°C;
- Hard and flat ground;
- It is prohibited to use in a flammable, explosive or corrosive environment with acid and alkali;

3. Technical parameters

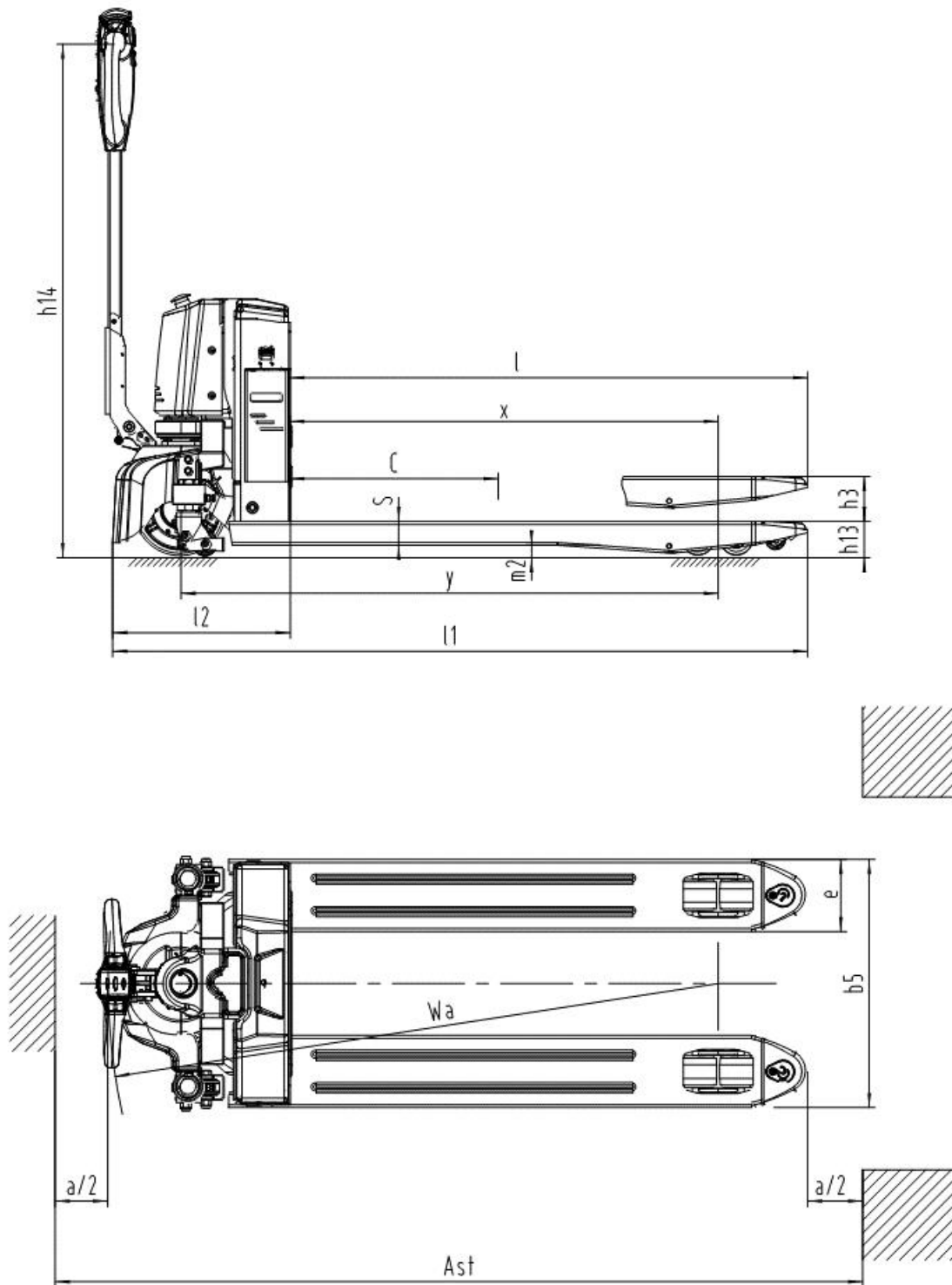

Figure 1

Characteristic	1.2	Model		CBD15W-IILi	CBD20W-IILi
	1.3	Drive: electric (battery type, mains, ...), diesel, petrol, fuel gas		Electric	Electric
	1.4	Operator type: hand, pedestrian, standing, seated, order-picker		Pedestrian	Pedestrian
	1.5	Load capacity	Q (kg)	1500	2000
	1.6	Load center distance	c (mm)	600	600
	1.8	Load distance, center of drive axle to fork	x (mm)	950/1020	950/1020
	1.9	Wheelbase	y (mm)	1195/1265	1195/1265
Weight	2.1	Service weight	kg	135	140
	2.2	Axle loading, laden front/rear	kg	665/970	870/1270
	2.3	Axle loading, unladen front/rear	kg	95/40	98/42
Wheel chassis	3.1	Tyres: solid rubber, superelastic, pneumatic, polyurethane		PU	PU
	3.2	Wheel size, front		$\Phi 210 \times 70$	$\Phi 210 \times 70$
	3.3	Wheel size, rear		$\Phi 80 \times 93$	$\Phi 80 \times 93$
				$\Phi 80 \times 70$	$\Phi 80 \times 70$
	3.4	Additional wheels (dimensions)		$\Phi 60 \times 35$ (option)	$\Phi 60 \times 35$ (option)
	3.5	Wheel number, front/rear (x = driving wheel)		1X/2(4)	1X/2(4)
	3.6	Tread, front	b_{10} (mm)	460	460
3.7	Tread, rear	b_{11} (mm)	390/520	390/520	
	4.4	Lift	h_3 (mm)	110	110
	4.9	Height drawbar in driving position min./max.	h_{14} (mm)	650/1135	650/1135
	4.15	Height, lowered	h_{13} (mm)	80	80
	4.19	Overall length	l_1 (mm)	1545/1615	1545/1615
	4.20	Length to face of forks	l_2 (mm)	395	395
	4.21	Overall width	b_1/b_2 (mm)	550/680	550/680
	4.22	Fork dimensions	$s/e/l$ (mm)	70/160/1150(1220)	70/160/1150(1220)
	4.25	Fork spread	b_5 (mm)	550/680	550/680
	4.32	Ground clearance, center of wheelbase	m_2 (mm)	27	27
	4.34.1	Aisle width for pallets 1000x1200 crossways	A_{st} (mm)	2150/2210	2150/2210
	4.34.2	Aisle width for pallets 800x1200 lengthways	A_{st} (mm)	2015/2055	2015/2055
	4.35	Turning radius	W_6 (mm)	1345/1415	1345/1415
Parameter	5.1	Travel speed, laden/unladen	km/h	4.3/4.5	4.6/4.8
	5.2	Lift speed, laden/unladen	m/s	0.025/0.030	0.020/0.025
	5.3	Lowering speed, laden/unladen	m/s	0.035/0.025	0.035/0.025
	5.7	Gradeability, laden/unladen	%	5/20	6/20
	5.10	Service brake		EM brake	EM brake
Motor	6.1	Drive motor rating S2 60 min	kW	0.75	1
	6.2	Lift motor rating at S3 15%	kW	0.8	0.8
	6.4	Battery voltage/nominal capacity	V/Ah	24/20	48/20
	6.5	Battery weight	kg	5	10
	10.7	Noise level at operator's ear, according to DIN12053	dB (A)	70	70

4. Assembly before operation

4.1 Handle assembly

The handle is removed before shipment in the consideration of the requirement of packing and the safety over transportation, and the steps to install the hand are list as following:

- As shown in Figure 2, take out the handle assembly 1, align it with the installation position A, and fix it reliably with screws 3 and washers 2.
- As shown in Figure 3, connect the connectors of the truck body harness 4 and the handle harness 5 (pay attention to the alignment direction). As shown in B, fix the harness firmly with the wire clamp 6 and the screw 7.
- As shown in Figure 4, fix the truck body harness 5 to the handle base 10 with screws 8 and line cards 9, press the handle down and slowly release it, observe whether the harness is properly fastened, and then test whether the truck functions normally according to the truck operation instructions.
- As shown in Fig. 5, fix the cover plate 12 to the handle assembly 13 with screws 11. After the above steps, the handle installation is completed.

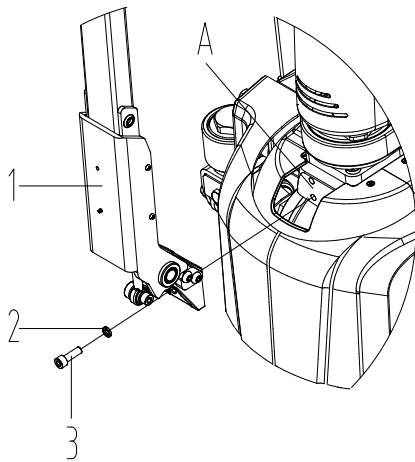

Figure 2

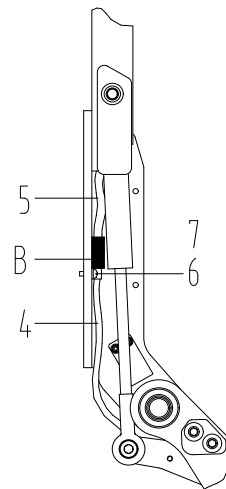

Figure 3

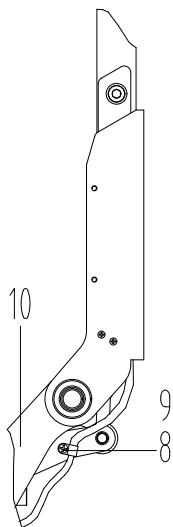

Figure 4

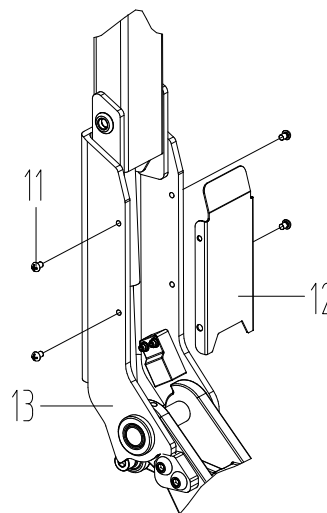

Figure 5

4.2 Oil tank cover assembly

In order to ensure safe transportation and packaging, the inverted and packaged fuel tank cover has been replaced with a sealed plug before leaving the factory. Therefore, users need to reinstall the fuel tank cover before use in order to use it normally. The installation steps are as follows:

- Refer to Figure 6, remove screw 1 and remove the housing 2;
- Refer to Figure 7 and remove the plug 3 on the oil tank;
- Refer to Figure 8 and install the tank cover 4 in the attachment onto the tank;
- Finally, install the housing 2 and screws 1 onto the truck body;

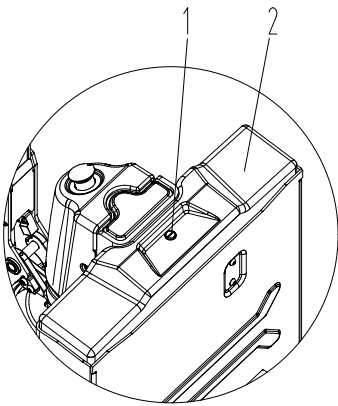

Figure 6

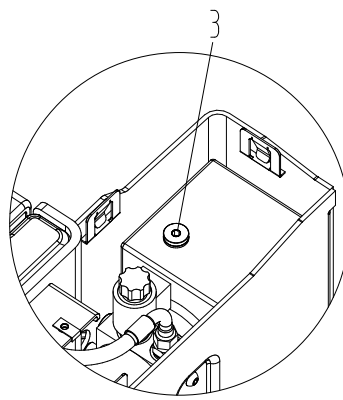

Figure 7

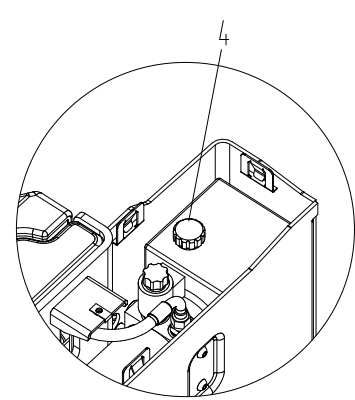

Figure 8

5. Operation

Truck electrified (magnetic lock)

- Turn on the electric lock
- Plug in the magnetic lock to turn on the truck easily.

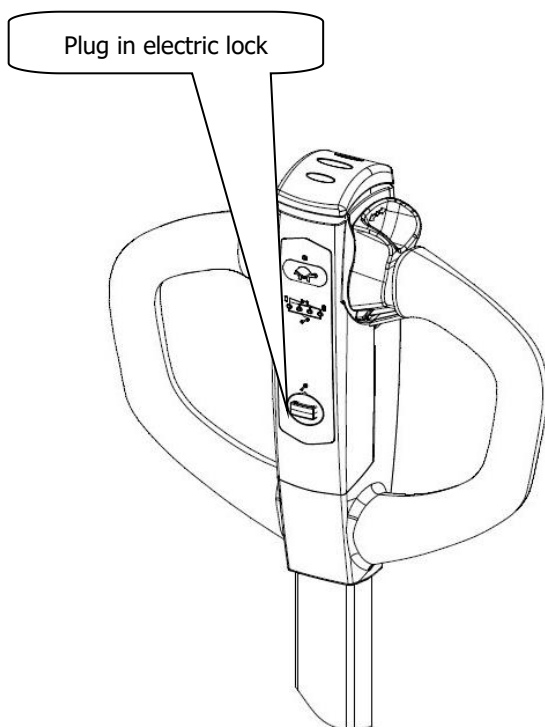

Figure 9

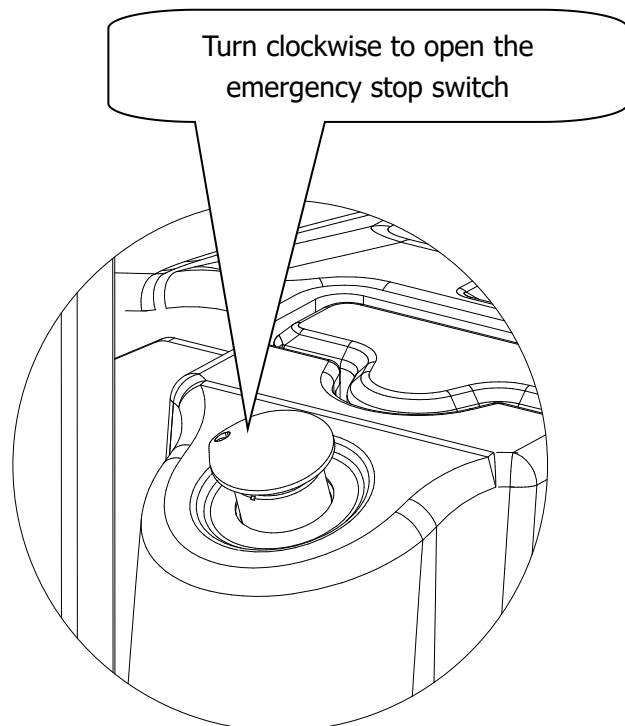

Figure 10

- Turn on the emergency stop switch

Truck electrified (password lock)

- Turn on the password lock by entering the right initial password 1234 and pressing ON.
- Password lock introduction

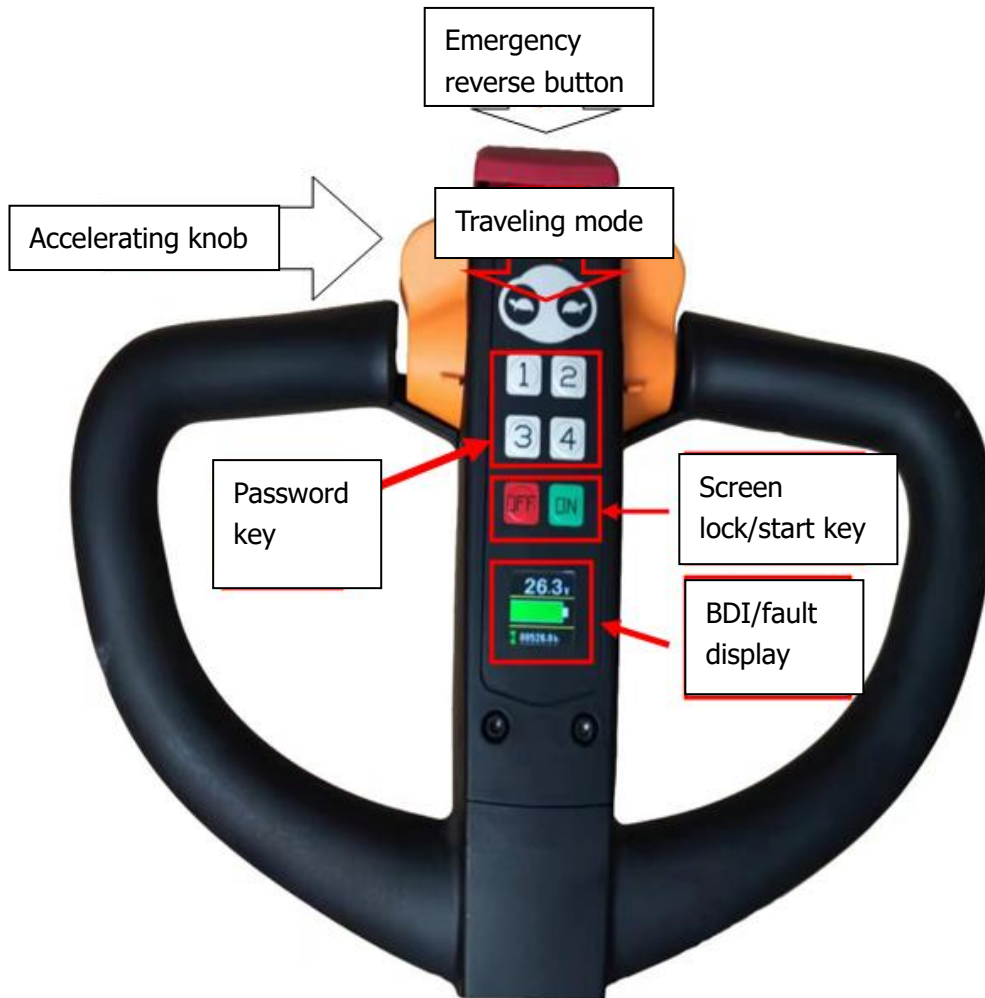

Figure 11

The instrument is able to display the voltage, battery capacity; it is also a working hour timer when the truck works normally. If a fault occurs, the fault code will be shown in the hour timer; if there are more than 2 fault codes, they will be displayed every 2 seconds in turn.

Change the password

Input 3232 when screen locked



Shows 0_0000



Input previous password and press ON



Figure 12

Display n_0000



Input new PIN code



Display C_PASS after successful PIN code change



Figure 13

Turn on the truck with a key

- Turn on the key switch
Insert the key to the lock and clockwise turn it by 90°
- Turn on the emergency stop switch

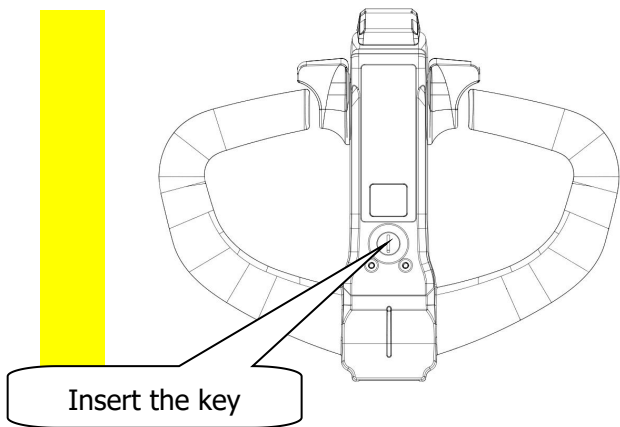

Figure 14

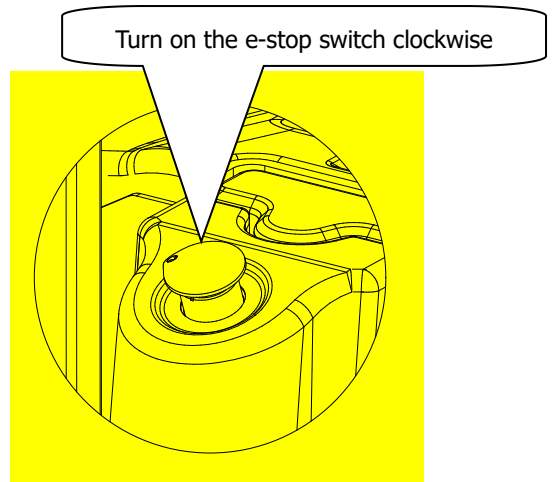

Figure 15

Fork lifting and lowering

- Lifting: Press the lifting button to lift
- Lowering: Press the lowering button to lower.

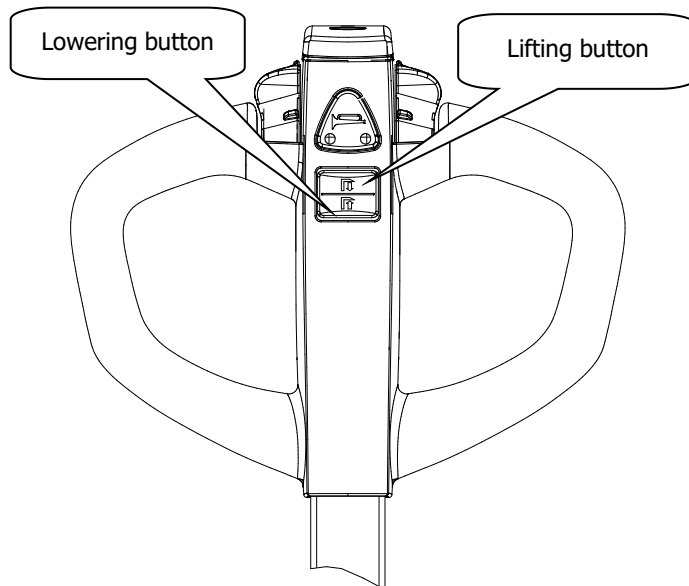

Figure 14

5.5 Traveling of the pallet truck

- Rotate the handle to the traveling zone:
 A and C are the braking zones;
 B is the traveling zone;

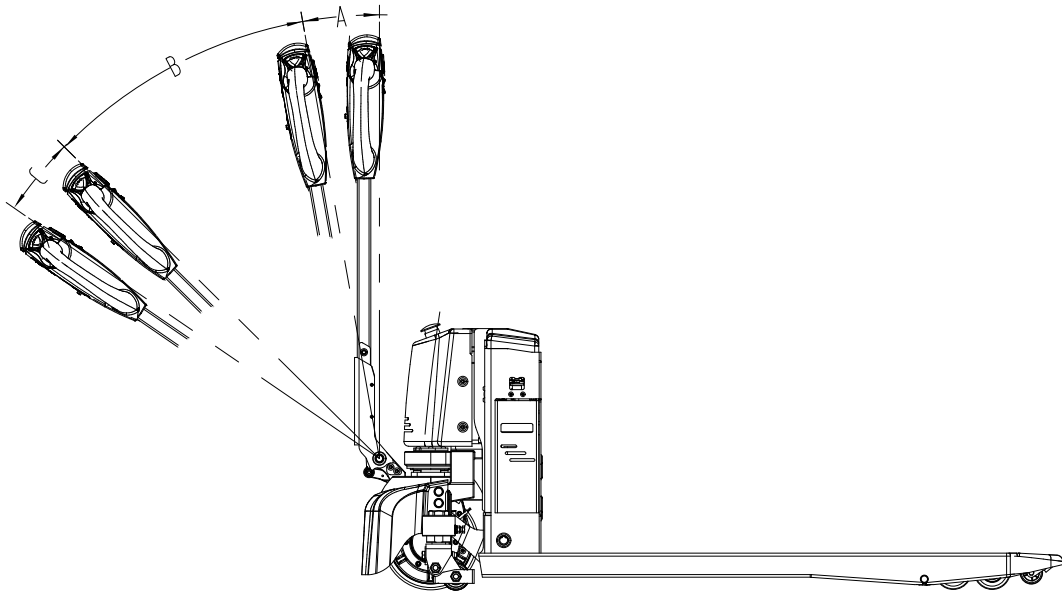

Figure 15

-Slowly rotate the accelerator to start. As shown in the figure, the rotation direction of the accelerator knob is the driving direction. The rotation angle of the knob is proportional to the driving speed. Release the accelerator knob and the knob will return to its original position automatically. At this time, the truck will slow down slowly until it stops (For safety reasons, do not accelerate rapidly)

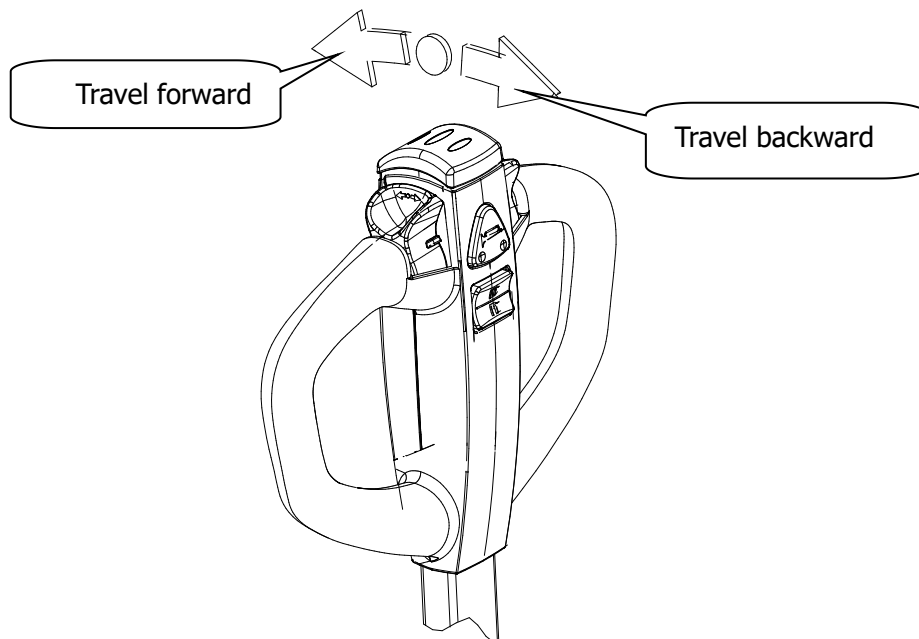

Figure 16

Braking

- When the accelerator is released during normal driving, the truck will slow down slowly until it stops, and finally the brake will automatically lock and park.
- Turn the handle to A or C quickly for emergency braking (Figure 15); the brake will lock the wheel to achieve an emergency braking.

Emergency reverse button

The emergency reverse button is at the end of the hand. When it's touched by operator's body, the truck will stop traveling immediately, and then travel backwards for a distance. The function is set to minimize

possible squeeze injuries when the truck encounters into obstacles over its traveling.

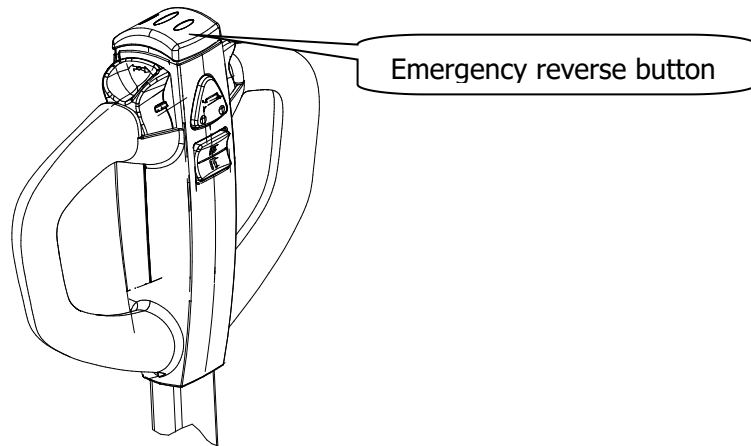

Figure 17

5.8 Parking

- Release the accelerator to stop the truck. The truck stops slowly until the brake engages and parks
- Lower the fork to the lowest position.
- Turn off the key switch.
- Disconnect the battery harness in order to park for a long time.

6. Use, maintenance and charging of storage battery

6.1 Battery maintenance

6.1.1 The battery type used is lithium ion battery, which is environment-friendly, free of chemical mercury, cadmium and other components.

6.1.2 Precautions

- ◆ Working ambient temperature of lithium battery is $-10^{\circ}\text{C} \sim 45^{\circ}\text{C}$.
- ◆ Charge and discharge the battery every 3 months when it is stored for a long time.
- ◆ Fully charge the battery before the first use or re-use after long-term idleness.
- ◆ Do not short circuit the battery, which may permanently damage it.
- ◆ Do not weld the battery by yourself.
- ◆ Do not keep the battery in an unfavorable environment, such as extreme temperature, deep cycle, or often overcharge or over-discharge.
- ◆ Do not touch the hot battery until it cools down.
- ◆ Taking down the battery by holding the plug, instead of pulling the charging line.
- ◆ The battery may be hot after charging, cool it down in a ventilated environment.
- ◆ Do not put batteries in water or sea water;
- ◆ Do not try to separate, squeeze, or hit the battery. Battery lye is harmful to skin and eyes, and will corrode clothes.
- ◆ Keep the battery out of children's reach.

6.2 Charging of battery

- When the battery indicator shows that the battery is low, charge it immediately, otherwise the battery will be damaged.
- Turn off the cable lock and emergency stop switch, connect the charging cable to the charging socket, and connect the plug to the power socket to start charging.
- When the charger indicator light is green, it indicates that the battery is fully charged. At this time, you can unplug the connecting cable.

6.3 Power display (magnetic lock)

- The green light is always ON: 78% - 100%
- Blue light is always ON: 52% - 77%
- Yellow light is always ON: 26% - 51%
- The red light is always ON: 16% - 25%
- Red light flashing: < 15%

When the red light is always on, please prepare to drive the truck to the charging place for charging; The red light flashes as a warning, indicating that the truck is about to stop working. Please charge the battery immediately. If it is used continuously, the battery life will be seriously damaged.

6.4 Power display (password lock)

- The green light is always ON: >50%
- The yellow light is always ON: 20%-50%
- The red light is always ON:<20%

6.5 Battery discharge display (key operated handle)

 The handle display shows the battery level in 10 segments. When the battery level is 2 segments or less, prepare to drive the truck to the charging area."

7. Maintenance

Whether a truck can be used satisfactorily depends on careful maintenance. Neglect of maintenance, which may endanger personal safety and damage property. Therefore, checks should be made regularly, abnormal phenomena should be eliminated in time, and faulty cars should not be used to ensure safety and prolong the service life of cars.

Maintenance of this pallet truck is generally divided into three levels: daily maintenance, weekly maintenance and Periodic Maintenance.

Daily maintenance: To keep the surface clean and examine if the power supply cable is damaged.

Weekly Maintenance: To check the condition of the operational components, all fastening items, if oil leakage, if abnormal wearing in mechanical components exists, if abnormal temperature rises or sparks in electric equipment, etc.

Periodic Maintenance

- a) Mechanical maintenance: do it every 6 months. Main content is to check whether the fasteners are loose, whether the wheels work flexibly and whether the fork lifts normally. The running noise of the truck after maintenance is not more than 75 dB.
- b) Hydraulic maintenance: do it yearly to check whether the cylinder is in normal condition, whether there are internal and external leakage. Whether the hydraulic oil is clean or not, which is usually replaced once in 12 months. Hydraulic oil adopts ISO standard. L-HV32 and L-HV15 cryogenic hydraulic oils are used when the ambient temperature is -5-40°C and -10-5°C respectively. The waste oil replaced shall be treated in accordance with the relevant local laws and regulations. Check whether the limit valve is working properly
- c) Electrical Maintenance: do it every 3 months to check whether the electrical connectors are reliable, whether the switches are normal, and check whether the electrical insulation is normal (the insulation resistance between the electrical part and the car body should be greater than 0.5MΩ).

7.1 Adding hydraulic oil

Add hydraulic oil as shown in Figure 18 as follows:

- First close the electric lock and emergency stop switch, and operate when power off;

- Remove the screw 1 and take out the cover 2;
- Remove the oil tank cap 3, add an appropriate amount of hydraulic oil into the oil filler, and the liquid level must reach 60% of the oil tank 4 (the oil tank is made of white plastic, and the liquid level can be observed externally).

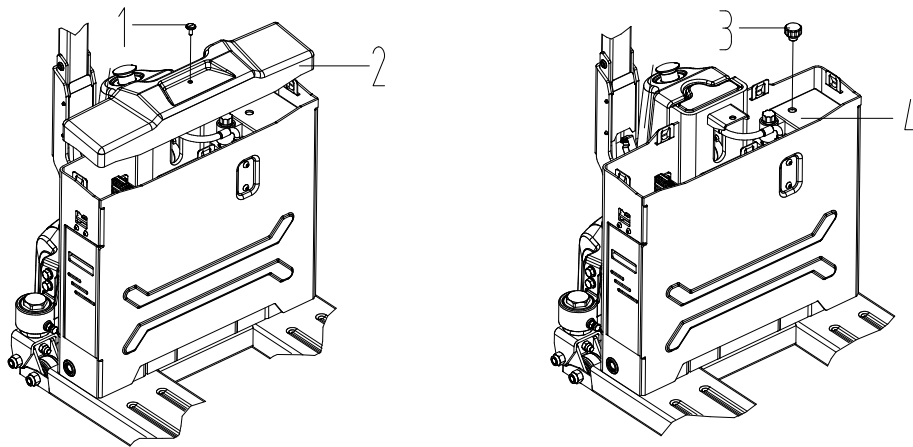

Figure 18

8. Truck hoisting

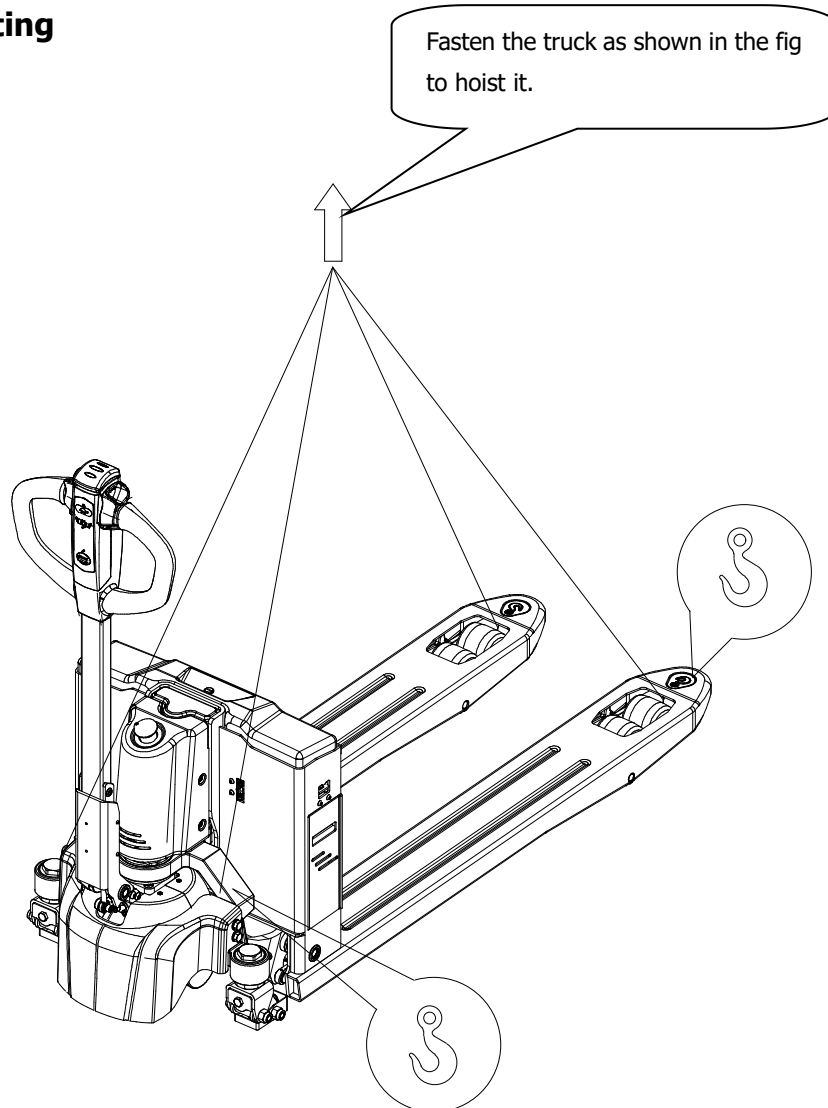

Figure 19

9. Trouble shooting

The table below provides some common failures of the truck in operation and the trouble shooting

No.	Fault	Cause analysis	Troubleshooting
1	Hydraulic oil leakage	<ol style="list-style-type: none"> 1. Seal failure; 2. The surface of some parts is slightly damaged or worn; 3. The joint is loose; 	<ol style="list-style-type: none"> 1. Replace the seal; 2. Replace the damaged parts; 3. Re tighten the loose parts;
2	Fork lifting failure	<ol style="list-style-type: none"> 1. The viscosity of working oil is too large or the working oil is not injected; 2. There are impurities in the oil; 3. The motor pump is damaged; 	<ol style="list-style-type: none"> 1. Change the working oil; 2. Remove the impurities in the oil circuit and renew the working oil; 3. Replace the hydraulic pump unit; 4. Readjust the relief valve value.
3	Fork lowering failure	<ol style="list-style-type: none"> 1. The manual lowering solenoid valve is stuck or damaged. 	<ol style="list-style-type: none"> 1. Replace the solenoid valve
No.	Fault	Cause analysis	Troubleshooting
4	Lifting motor failure	<ol style="list-style-type: none"> 1. The power supply is not turned on; 2. The battery has been completely discharged; 3. Motor damage; 4. The fuse is blown; 	<ol style="list-style-type: none"> 1. Turn on the power supply; 2. Charge; 3. Check whether the travel switch on the handle is pressed down due to collision and whether the brake is damaged; 4. Replace the fuse;
5	Charging failure	<ol style="list-style-type: none"> 1. Charger is damaged 2. Battery is damaged 3. Wiring failure 	<ol style="list-style-type: none"> 1. Replace a charger 2. Replace a battery 3. Check the charging wiring

10. Waste treatment

The abandoned batteries and hydraulic oil should not be placed carelessly and must be treated according to the relevant local regulations and laws. Attention must be paid to environmental protection.

11. Accessories and spare parts

No.	Name	Application site	Specification	Qty(pc)	Remarks
1	Key	To the lock		2	
2	Charger	Charge the battery		1	

12. Electrical schematic diagram and fault code

12.1 Magnetic-lock handle /key operated handle (1.5T)

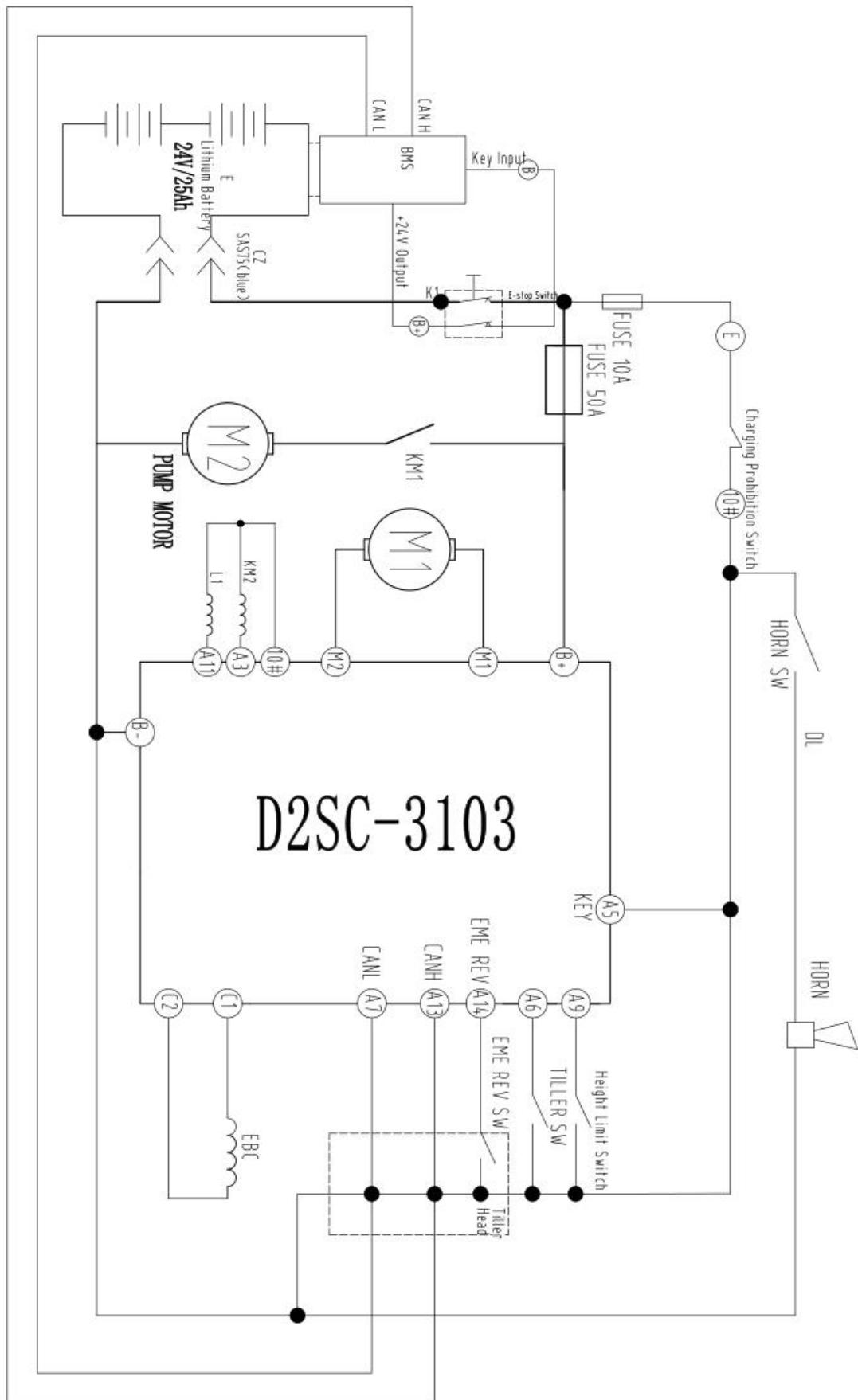

12.1.2 Fault code table

Fault English	Fault code
Hardware Fault	42
Current Sense Fault	41
Precharge Fault	33
Brake On Fault	32
Battery Disconnect Fault	45
Parameter Fault	43
Brake Off Fault	34
Main Relay DNC	21
Wiring Falut	31
Main Driver Fault	23
Main Relay Welded	24
Throttle Fault	12
HPD Fault	35
EMR Sequencing Fault	22
Overvoltage Cutback	15
Undervoltage Cutback	14
Controller Overtemp Cutback	11
Pump SRO Fault	25
Creep Mode Fault	26
SRO Fault	27
Software Fault	36
Motor Temp Hot Cutback	44
Motor Overtemperature	46
Low BDI	51
Controller Overcurrent	52
Controller Severe Overtemp	53
Controller Undertemp Cutback	54
Parameter Change Fault	55
Severe Overvoltage	56
Motor Short	61
Motor Open	62
Gage PDO Timeout	63
PDO Timeout	64
BMS PDO Timeout	65
Driver 1 On Fault	66
Driver 2 On Fault	67
Driver 1 Off Fault	71
Driver 2 Off Fault	72
Severe Undervoltage	29

12.2 EURO type (1.5T)

12.2.1 Electrical schematic diagram

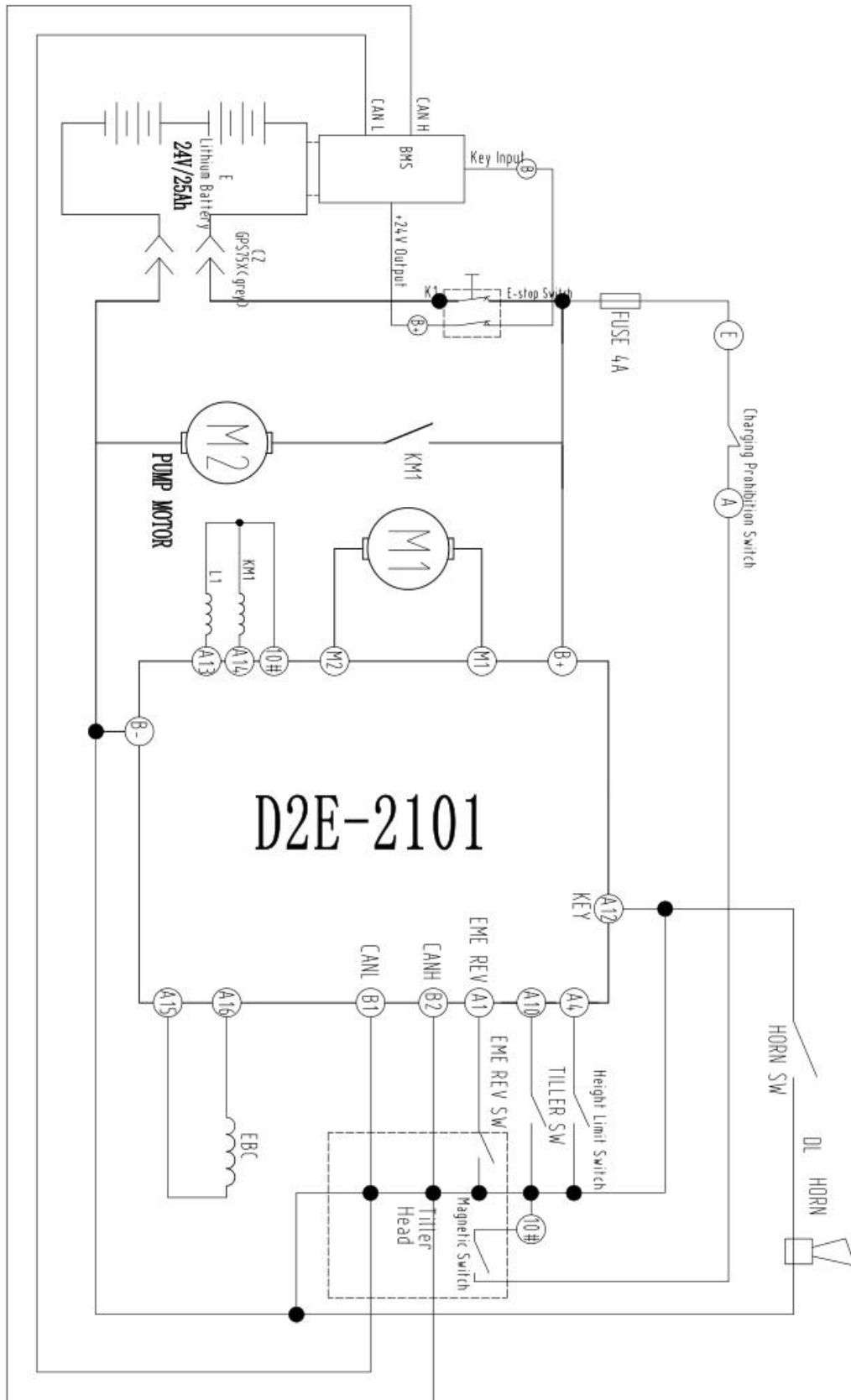

12.2.2 Fault code table

See 12.1.2

12.3.2 Fault code table

LED error code

Code	Fault description	Trouble shooting
1	Feedback overspeed	If the controller fails, contact the manufacturer.
2	Kernel running error	If the controller fails, contact the manufacturer.
8	Loss of speed sensor	No speed feedback detected. Treatment method: 1. Check the connection between speed sensor and controller; 2. Check whether the signal of the speed sensor is normal; 3. Check the detection circuit of the controller.
9	The speed sensor is in the wrong direction.	The direction or phase of Hall sensor ABC and motor UVW are inconsistent. Workaround: 1. Adjust Hall phase by controller parameter P47; Every increase 30, until the motor rotates normally. Then adjust 50 each time to find the motor. The range that can rotate normally. Finally, the midpoint of the range is set as the parameter value. 2. If the method of 1 cannot solve the problem, change the parameter P3.0 (feedback After reversing), repeat step 1.
11	2-minute maximum current protection of motor	The current of the motor lasts for more than 2 minutes and the maximum current lasts for more than 2 minutes. 1. The motor is locked; Check whether the brake is turned on or not, and check whether there is any foreign matter. Jam the drive mechanism. 2. Improper setting of controller parameters, see motor parameter adjustment for details.
12	Controller overcurrent	Possible reasons:

		<ol style="list-style-type: none"> 1. The motor is short-circuited. 2. The direction or phase of Hall sensor ABC and motor UVW are inconsistent. 3. The motor parameter P15 is set incorrectly in the field weakening base speed. 4. If the controller fails, contact the manufacturer.
13	Bus charging fault	<p>Bus charging timeout. Workaround:</p> <ol style="list-style-type: none"> 1. check whether there is a short circuit between the three phases of motor u, v and w. 2. Check whether the battery voltage supply is too low. 3. Check whether the drive coil is short-circuited (DO circuit and battery B-). 4. Check whether the DO+ terminal supplies power to devices other than DO.
14	Main contactor connection failure	The internal contactor of the controller is abnormal.
15	DRIVER1 connection failure	Check whether the DRIVER1 connection is normal.
16	Battery voltage is seriously too low.	Check the battery power; Or the battery voltage level of the controller is set incorrectly.
17	Battery voltage is too high	Check the battery voltage; Or the battery voltage level of the controller is set incorrectly.
18	The power of the board is seriously over-heated.	Controller protection, suspended.
20	Abnormal accelerator/brake pedal input	<p>The accelerator pedal or brake pedal input signal is abnormal. Workaround:</p> <ol style="list-style-type: none"> 1. Check the connection between pedal and controller for short circuit and open circuit. 2. Check whether the pedal is damaged; 3. Check the parameter settings of the controller related to the pedal, especially the pedal class. Type. (P91, P101)。
21	reserve	

22	5V output fault	1. Short circuit of motor encoder; 2. Other 5V external devices are short-circuited; 3. If the controller fails, contact the manufacturer.
23	MACID detection failed.	The CAN network ID number setting of the controller is repeated, and it is reset.
24	Main contactor drive failure	The internal contactor of the controller is abnormal.
25	Power module failure	Controller failure.
26	CAN node lost	1. the controller is configured in parameter P1, and the interlock check is enabled in parameter P2. Check. In practice, the corresponding module was not found. 2. Check the connection between modules and the working status of modules.
29	The internal temperature measuring circuit of the controller is abnormal.	If the controller fails, contact the manufacturer.
31	Battery voltage is slightly too low	The battery is low, so charge it as soon as possible.
32	Slight overtemperature of board power	Because of slight over-temperature, the controller reduces the load.
33	Board low temperature	The environment is too low, and the controller reduces the load.
34	Slight overtemperature of motor	Reduce load usage.
35	reserve	
36	2 Drive2 connection failure	Check the Drive2 connection.
37	3 Drive3 connection failure	Check the Drive3 connection.
38	Error in EEPROM reading and writing parameters	If the controller fails, contact the manufacturer.
39	Parameter overrun error	If the parameter is set up, contact the manufacturer.
40	Operation timing error	After reset, the key signal is not in the original position (throttle switch, direction switch, up Up/down, safety switch, emergency switch). Signal homing, automatic alarm Eliminate.
41	20% remaining power alarm	charge

42	15% remaining power alarm.	charge
43	Unmatched alarm	The matching enable parameter is set, but the matching has not been completed. See automatic horse for details. With instructions.

13. Packing list

Electric Pallet Truck Packing List

Consignee:
Contract No.:

Ex-work No:
Ex-work Date:

No.	Product Name	QTY	Net. Weight (kg)	Dimension (L×W×H)	Remarks
1	Pallet truck	1			A complete set
2	Accessory box	1			Technical documents, accessories and spare parts.

Note: 1. The following documents are in the file bag:

- a) Operation manual 1 volume
- b) Parts catalogue 1 volume
- c) Qualification certificate 1 copy
- d) Packing list 1 copy

2. Accessories and spare parts

No.	Name	Application site	Specification	Qty(pc)	Remarks
1	Key	To the lock		2	
2	Charger	Charge the battery		1	

Consignor: