

SPS150/SPSA150 Hydraulic Lift Table

- **Operation manual**
- **Parts catalogue**

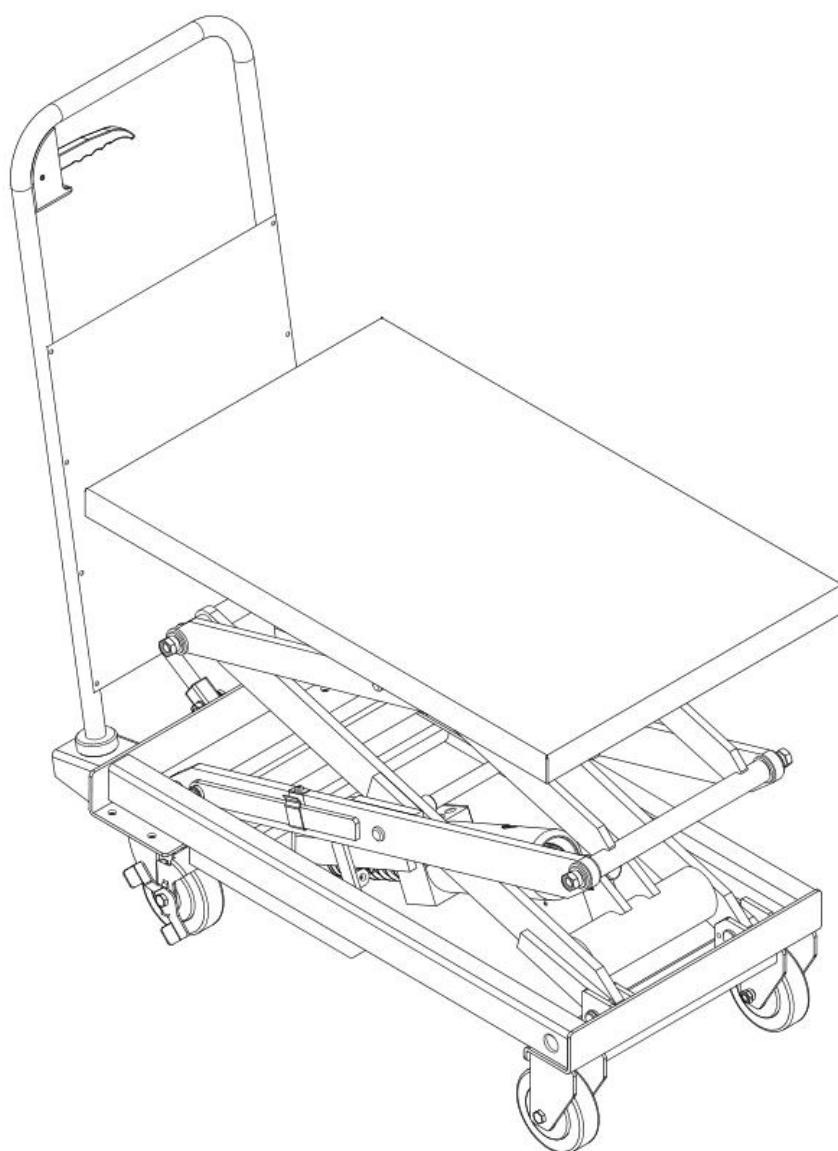

I. Outline diagram

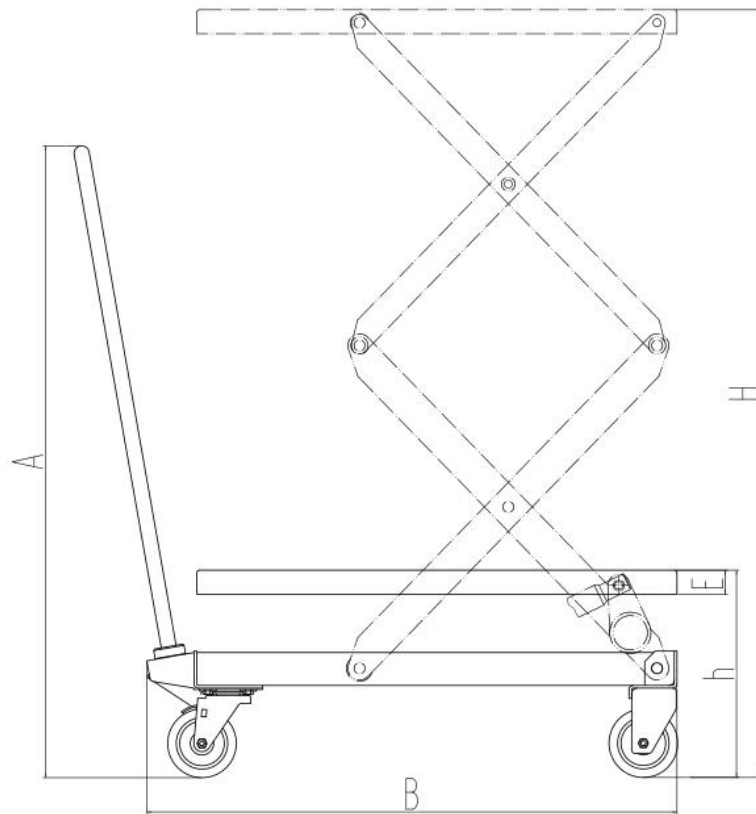

II. Basic parameters

Model		SPS150/SPSA150
Load capacity	kg	150
Max. lift height H	mm	1100
Min. height of table h	mm	302
Table size L×C×E	mm	700×450×35
Handle height A	mm	921
Overall length B	mm	773
Foot pedal cycles to max. height		≤30
Wheel diameter D	mm	100
Working volume of oil cylinder	ml	115
Oil capacity	ml	250
Service weight	kg	64

III. Scope of application

SP series table lift truck is a kind of high-lift transportation tool which is applicable for short-distance transportation as well as goods lifting and lowering. Besides, it can also be used as station facilities for workshop.

IV. Environmental conditions for use

1. Solid and flat ground;
2. Working temperature: -20-40C°.

V. Precautions

1. Before use, it is necessary to carefully read the manual, understand the performance and usage requirements. Use with authorization.
2. Wear work clothes, safety shoes, and gloves when operating.
3. To ensure normal and safe operation, please purchase any accessories required from designated suppliers and manufacturers.
4. After overhaul and major component replacement, the truck must be retested and confirmed to be safe before reuse.
5. Only designated trained and qualified personnel can operate and use the truck.
6. Do not overload and use within the rated load. Overloading will cause injury to the human body and damage to the truck.
7. Do not stand or sit on the table.
8. Do not place hands or feet under the falling table.
9. When loading goods, please brake properly to prevent the truck from moving;
10. When loading goods, must evenly distribute the goods on the entire table;
11. It is not allowed to load loose or unstable goods;
12. Do not leave goods on the table for a long time;
13. The truck cannot be moved while the goods are being lifted;
14. The truck can only be used on flat and hard ground, and it is prohibited to use it on slopes or uneven ground;
15. When placing goods on a lifted table, it is important to ensure that the weight of the goods should be within the rated load and be placed evenly (the safety valve only functions during the lifting process. If the truck has been lifted and overweight goods are placed, the safety valve cannot function, which may damage and disable the truck).
16. When loading and unloading goods on a lifted table, be careful not to drag laterally, as it may cause serious eccentric loads and cause the truck to tip over, resulting in accidents;
17. To ensure safety during repairing and maintaining, be sure to use a support rod to support the scissor arms so that the table does not fall (the table should be unloaded).
18. Strictly follow the precaution list; otherwise, it will cause damage to the human body and the truck.

VI. Operation

1. Step on the foot lever for several times to lift the table.
2. Lift the handle knob upward slowly, and open the one-way valve to lower the table slowly.
3. Release the brake before moving the truck.
4. Brake operation

When the truck is being lifted or lowered, it is prohibited to operate the brake, and must not place any part of the foot or body on the brake position

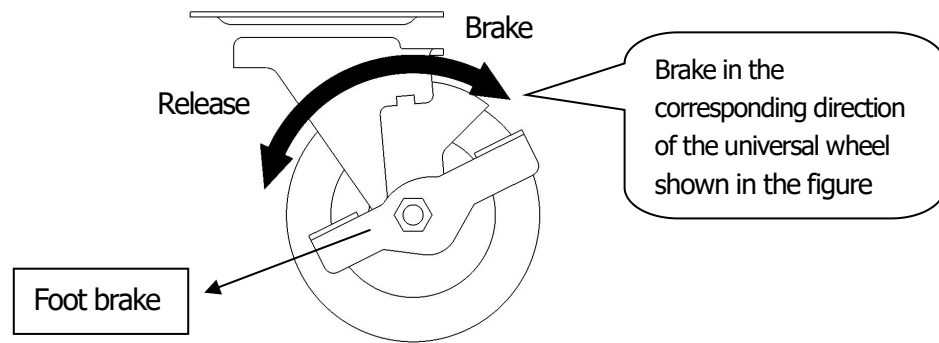

VII. Maintenance and upkeep:

It is very important to conduct necessary maintenance so as to prolong the service life and safety of the lift table. Check the lift table before operation according to the following items:

1. Whether there is any distortion and bending of the truck.
2. Check the brake and the wearing condition of the wheels.
3. Check oil leakage in the hydraulic system.
4. Add or fill lubricant to each friction surface before daily operation.
5. Do not use a faulty truck until it is fixed.
6. Change the hydraulic oil every 12 months. Choose the following or close brand hydraulic oil according to the climate conditions of different areas:
 - a) When the working environment is $-10\sim+40^{\circ}\text{C}$: YBN32
 - b) When the working environment is $-20\sim+40^{\circ}\text{C}$: YCN32.
7. Oil replacement

Screw out the 11# sealing screw in the pump (see figure 1 in the appendix) with a wrench; Pull the knob up; Unscrew the oil plug screw 39# and add hydraulic oil;
8. Materials of the sealing parts 1#,3#,4#,16#,25#,26#,32#,35#,36#,42#,43#,45#,48#,49# of the pump(see figure 1 in the appendix) is rubber, PU, whose maintenance interval is 2-year. Replace the sealings in time to avoid possible damage and poor performance of the truck.

VIII. Trouble shooting

Fault	Possible causes	Trouble shooting
The table fails to lift or insufficient lifting height	1) Steel ball (20) of the check-valve is not closed down. 2) Firing pin (31) withstands the steel ball (20). 3) Short of hydraulic oil.	1) Clean the valve opening and change the steel ball (20). 2) Adjust the tension of the steel wire rope to make firing pin at suitable place, and add or fill lubricant to the pin roll (33) 3) Add enough hydraulic oil.
The table lowers after being lifted	1) Steel ball (20) (27)of the check-valve is not closed down. 2) Firing pin (31) withstands the steel ball (20).	1) Clean the valve opening and change the steel ball (20)(27). 2) Adjust the tension of the steel wire rope to make firing pin at suitable place, and add or fill lubricant to the pin roll (33)
The table fails to lower	The travel of the firing pin (31) is not enough to open the steel ball (20).	Adjust the tension of the steel wire rope to make firing pin at suitable place, and add or fill lubricant to the pin roll (33) .
Oil leakage at firing pin.	The O- ring (32) is damaged.	Change the O- ring (32).
Oil leakage at pump (2), pump core (5) and piston rod (44).	The seal ring (1)(3)(48)(49) are damaged.	Change the seal ring (1)(3)(48)(49)

The above parts are detailed in the figure 2.

IX. Assembly method

The handle and the foot brake lever of the SPS150/SPSA150 lift table is disassembled before delivery. The user need to assemble them before use:

1. Handle assembly: according to the parts exploded picture, fix the handle to the mounting hole of the truck body with bolt, spring washer, flat washer, then screw down the bolt with a wrench.
2. Foot brake lever assembly: insert the foot lever (24) into the hole of the square bar (21) , screw in the screw(23), then put in the plain washer (6) and the spring washer (7) respectively and screw down the nut (8).

X. Structure diagram and schematic diagram

Assembly see figure (1)

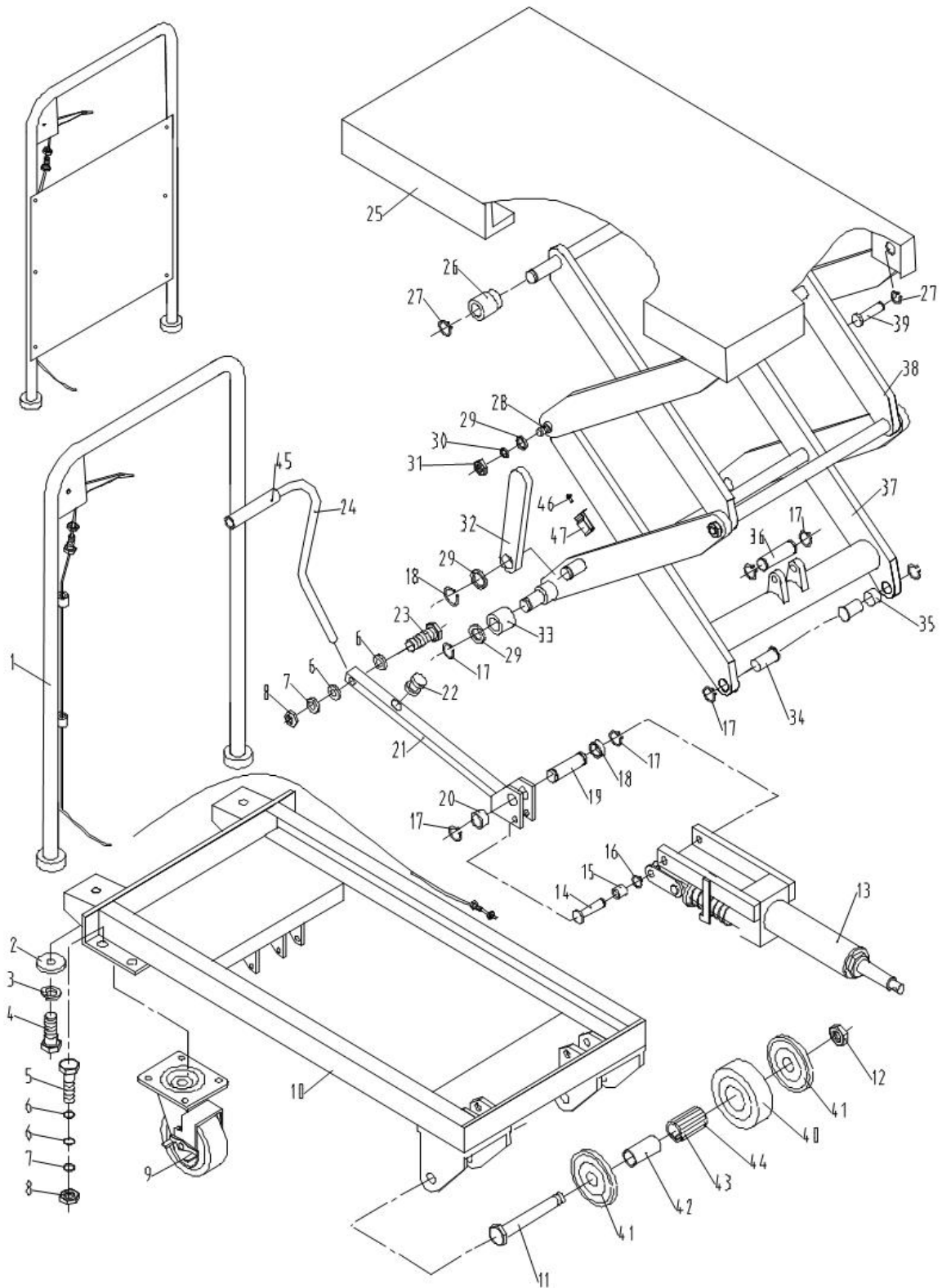

Pump see figure (2)

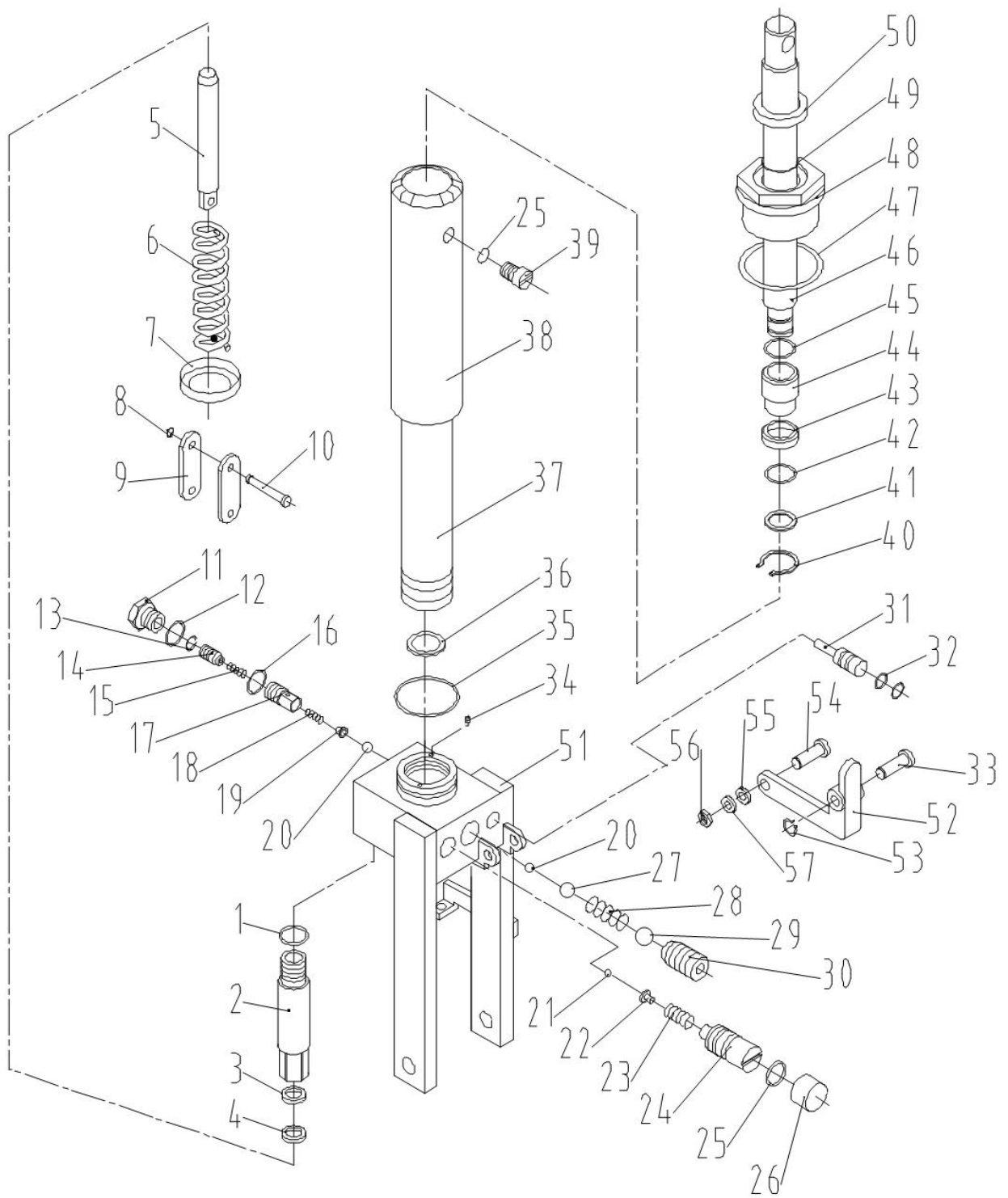

Hydraulic schematic diagram see figure (3)

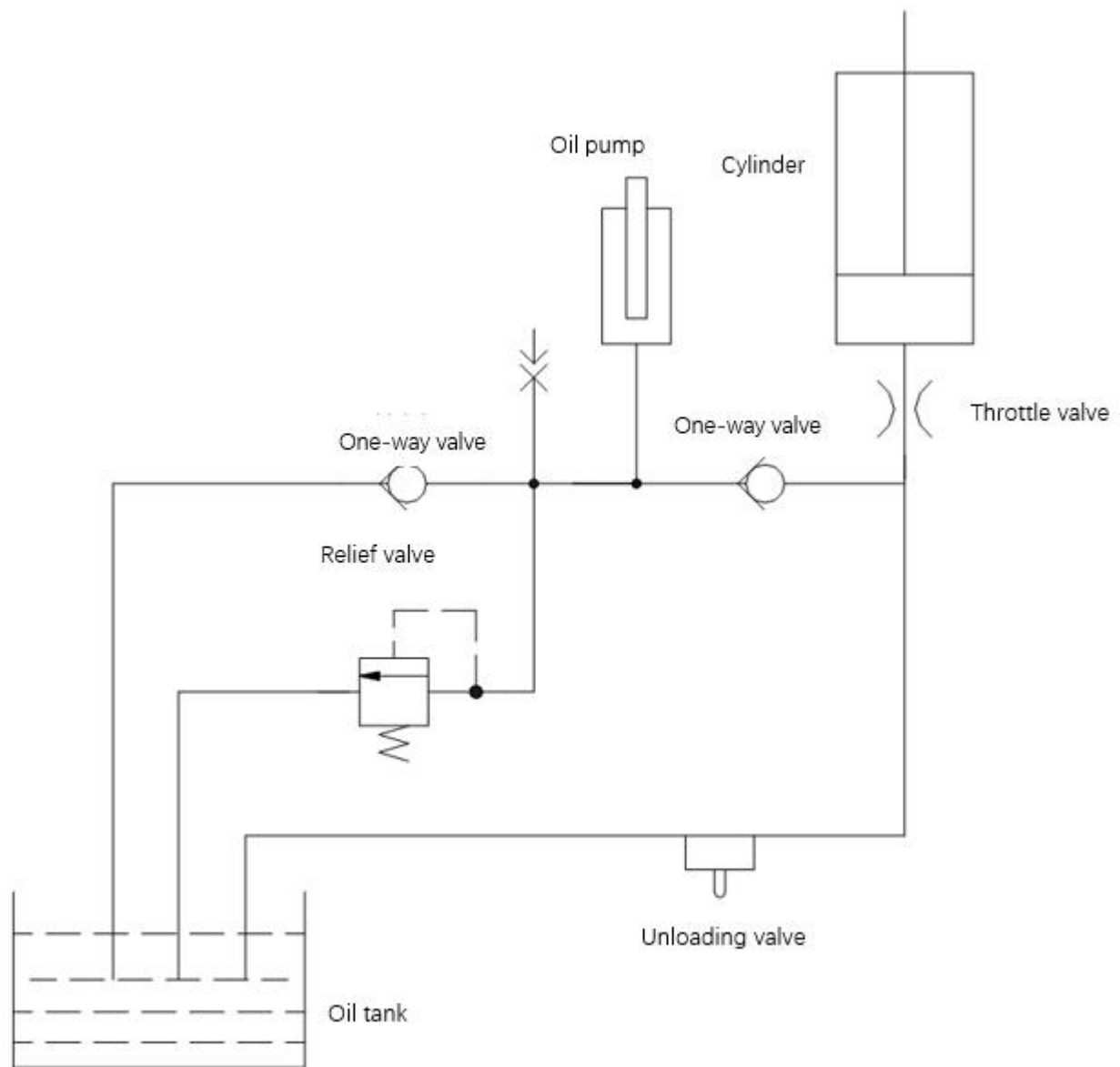

Working Principle

1. When unloaded, the throttle and constant pressure overflow valve simultaneously drain oil, resulting in rapid lower, which can meet customer requirements.
2. When the load is greater than 50kg and the system pressure is greater than 8MPa, the constant pressure overflow valve automatically closes, and the hydraulic oil slowly drains through the throttle, leading to slow lower, meeting the requirements of safety standards.