

# **SDJAS Manual Stacker**

- **Operation Instruction**

- **Parts Manual**

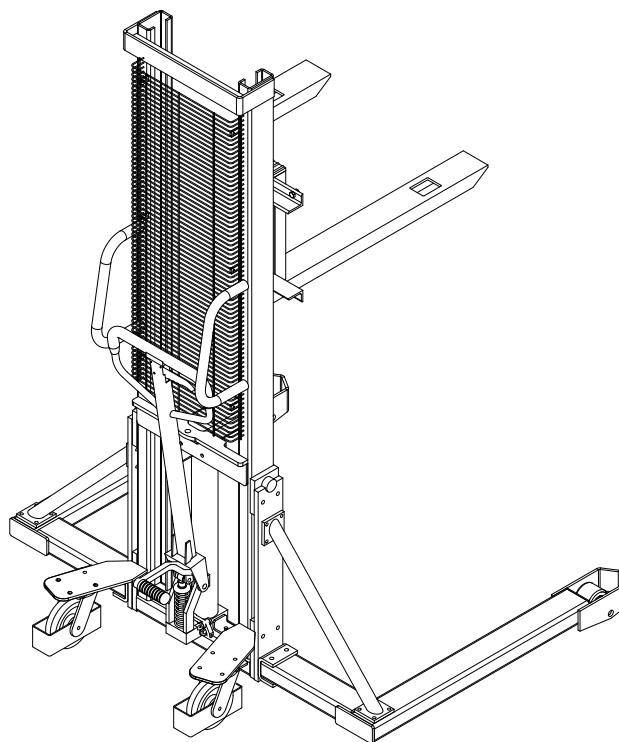

**Thank you for choosing SDJAS manual hydraulic stacker.**

**We hope it will provide great convenience to your work!**

- **Please read the manual carefully before operation**
- **This is a universal manual. We reserve the right to modify technology of the electric pallet truck. If there is anything in the manual that is not consistent with the actual truck, the actual one should be considered correct and the manual is only for reference.**

\*\*\*\*\*



**Warning!**

Pay attention to the following matters before operating this stacker:

1. SDJAS manual stacker can only be operated indoor on even and solid ground and it is strictly prohibited to operate the stacker in a corrosive environment with acid and alkali.
2. Please read this manual carefully and understand the performance of the stacker before operating; Inspection of the stacker should be conducted carefully every time before operation to ensure that the stacker is in normal condition. It is strictly prohibited to operate a faulty stacker.
3. It is strictly prohibited to overload the stacker. The load capacity and the load center should meet the requirements in the parameter table of this manual.
4. When stacker is used for piling, the gravity center of the goods must be within the two forks and it is strictly prohibited to pile loose goods.
5. When it is required to transport the goods for a comparatively long distance, the height of the forks from the ground should not exceed 0.5m.
6. When piling goods, it is strictly prohibited for people to stand under the forks or around the stacker.
7. It is strictly prohibited to stand on the forks for operation.
8. When the goods are on high level, the goods should be pushed forward or pulled backward slowly and no cornering is allowed in such a case.

**I. Outline drawing and Key technical parameters:**

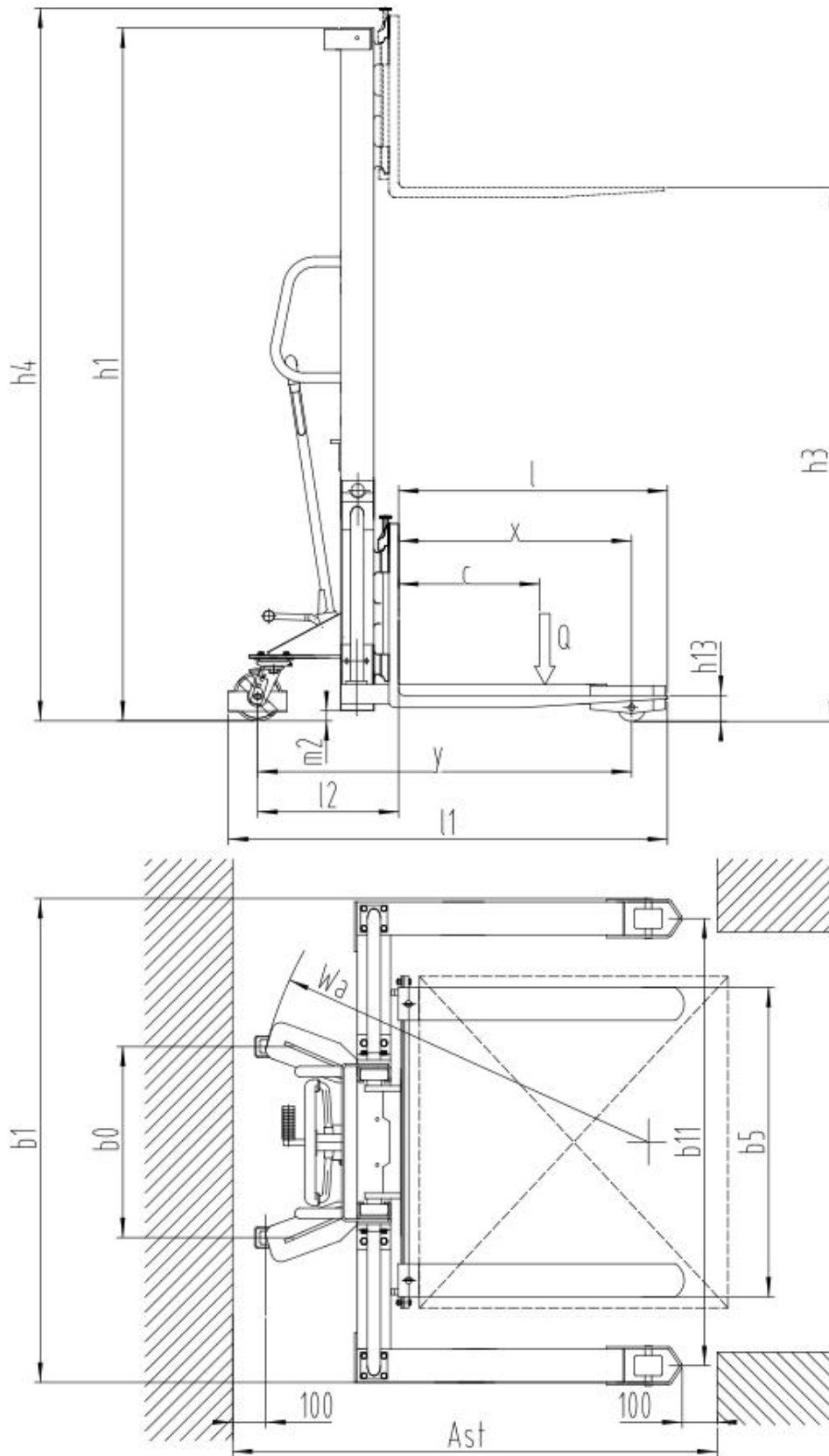

Characteristics	1.1	Manufacturer (abbr.)				
	1.2	Type designation		SDJAS500	SDJAS1000	SDJAS1000
	1.4	Drive type		Manual		
	1.5	Rated capacity	Q(kg)	500	1000	1000
	1.6	Load capacity at load center distance	$c$ (mm)	500	500	500
	1.8	Load distance	$x$ (mm)	687 (947)	725 (985)	737 (967)
	1.9	Wheelbase	$Y$ (mm)	1087 (1347)	1087(1347)	1087 (1347)
Weight	2.1	Service weight	kg	223 (235)	294 (314)	350 (370)
Wheel chassis	3.1	Tyres		Nylon		
	3.2	Tyre size, front		$\Phi$ 150X40		
	3.3	Tyre size, rear		$\Phi$ 83X60		
	3.5	Wheels,number front/rear		2/4		
	3.6	Tread, front	$b_{10}$ (mm)	612	732	681
	3.7	Tread, rear	$b_{11}$ (mm)	1370	1350	1350
Dimension	4.2	Height,mast lowered	$h_1$ (mm)	1990	2070	1820
	4.4	Lift height	$h_3$ (mm)	1600	1600	2500
	4.5	Height, mast extended	$h_4$ (mm)	1990	2105	3005
	4.15	Fork height	$h_{13}$ (mm)	70		
	4.19	Overall length	$l_1$ (mm)	1350 (1610)		
	4.20	Length to face of forks	$l_2$ (mm)	400	362	380
	4.21	Overall width	$b_1$ (mm)	1490	1475	1475
	4.22	Fork dimensions	S/e/l(mm)	48x100x800 (1060)	30x100x800 (1060)	
	4.25	Fork spread	$b_5$ (mm)	200~745	200~950	
	4.32	Ground clearance, center of wheelbase	$m_2$ (mm)	30		
	4.33	Aisle width for pallets 1000 × 1200 crossways	$A_{st}$ (mm)	2065 (2315)	2072(2322)	2067 (2317)
	4.34	Aisle width for pallets 800 × 1200 lengthways	$A_{st}$ (mm)	(2315)	(2322)	(2317)
4.35	Turning radius	$W_a$ (mm)	1220 (1470)	1235(1485)	1230 (1480)	
Performanc e Data	5.2	Lift speed, laden/unladen	mm/s	23/25	20/22	20/22
	5.3	Lower speed, lade/unladen	mm/s	143/53		
	5.10	Service brake		Mechanical braking		
	8.4	Noise level at operator's ear, according to DIN12053	dB(A)	<70		

## **II. Structural characteristics and working principle**

SDJAS 500 manual stacker consists of a hydraulic system, mast and forks.

The stacker uses a manual hydraulic pump (hydraulic device) as force to lift heavy goods, which are pushed, pulled and handled manually. The hydraulic device is equipped with an oil return valve and the fork decline speed is controlled via a hand lever to make the operation of the hydraulic system correct, safe and reliable. The mast is welded with high quality profile steel such as to good rigidity and high strength. Universal wheels with braking device are adopted as the back wheels, which can rotate freely, easily and flexibly. Both front and back wheels are installed on wheel shafts with ball bearings so as to rotate flexibly. Wear-resistant and durable Nylon wheels are adopted so that it is not easy to damage the operation ground.

When lifting goods, insert the forks under the pallet of the goods, when necessary, break the back wheels and pull the hand lever. The pinch roller presses the pump core to make the oil in the pump cylinder flow into the piston cylinder, in order to push the piston rod move upward and lift the forks upward via a chain for a two times travel. Pull the hand lever back and forth so as to lift the goods and achieve the purpose of lifting. When the forks are lifted to the maximum height, the pressurized oil flows back into the oil tank via an oil draining hole and in that case, even the hand lever is pulled, the forks raise no more to avoid damaging components by impacting the top.

When handling heavy goods, the stacker is able to travel via manual pushing (pulling).

When unloading, pull the unloading handle and open the oil return valve. Under the self weight of the heavy object and fork, the working oil in the piston cylinder returns to the oil tank through the oil return valve. When the piston rod and fork drop to the lowest position, remove the heavy object and draw out the fork.

## **III. Operation conditions**

The operation of SDJAS 500 manual stacker should meet following conditions:

1. Ambient temperature for operation:  $-25^{\circ}\text{C}\sim+40^{\circ}\text{C}$ .
2. The relative humidity of the environment should be less than 90%RH.
3. The stacker can only operate in an environment without rain and harmful gas erosion.
4. The stacker can only operate indoor on even and solid ground.

## **IV. Operation and maintenance**

1. The oil must be filtered and clean and ensure sufficient oil quantity.
2. Before operation, inspection must be conducted for the stacker to ensure the stacker is in normal condition and there is no loose component.
3. The goods should be smoothly distributed on the forks and no overload is allowed.
4. After the operation is completed, the goods should be unloaded and the heavy good are not allowed to be on the forks for a long time.
5. When lowering goods, the hand lever of the oil return valve should be operated slowly and gently to avoid sudden declination during quick declination process which causes unsafe situation. When lowering the goods quickly, the oil return valve can not be closed suddenly as inertial acceleration is generated during the process of quick declination. If that, a great force will be generated to damage

the components and goods.

6. Raise and pull outward the front part of the panel by hands, take off the panel and then the stacker can be used as pallet truck cart or pallet stacker.
7. The brakes on back wheels are installed for the purpose of safety in operation process. When the forks are rising for lifting goods or is used as an operation platform, the brakes should be stepped down with foot to prevent the stacker from moving.

## V. Possible failures in operation and trouble shooting

No.	Failure	Cause analysis	Trouble shooting
1	The lifting height cannot meet the design requirement	Insufficient operation oil	To fill oil into the oil cylinder, turn out the bolt, fill in filtered and clean operation oil to the oil inlet height and then tighten the bolt.
2	When the hand lever is pulled, the forks do not rise.	1. The viscosity of the operation oil is too great or no operation oil has been filled in	Replace or fill in operation oil according to the oil quantity regulated.
		2. There is foreign matter in operation oil, which makes the oil inlet valve cannot be tightly closed.	Filter out the foreign matter or replace operation oil according to the stipulation.
		3. The oil draining valve, unloading hand lever and tension spring do not work and not at the lowest position or blocked by other foreign mater.	Examine the tension spring to see if it is correct, adjust the unloading hand lever to the lowest close position and remove foreign mater.
		4. The positions of the oil draining valve and unloading hand lever have not been correctly adjusted.	Readjust the unloading tension bar nut position.
3	After being lift, the fork fails to lower	<ol style="list-style-type: none"> <li>1. The unloading hand lever is not correctly adjusted.</li> <li>2. Over heavy load deviation so the piston permanent deformation occurs.</li> <li>3. The fork frame, roller or chain wheel is block.</li> </ol>	Adjust as described above, disassemble for maintenance or replace the piston rod, disassemble for maintenance or replace bearing
4	Oil leakage	<ol style="list-style-type: none"> <li>1. Damaged or failed seal washer</li> <li>2. Slight crack or through holes in individual component</li> <li>3. Loose thread connection or non-tightly pressed sealing ring</li> </ol>	Replace with new sealing washer, repair or replace new components, repair and tighten

## VI. Packing list

### SDJAS Manual Stacker

Consignee:  
Contract number:

Ex-factory number:  
Ex-factory date:

No.	Name	Quantity	Dimension (L×W×H)	Remark
1	SDJAS manual hydraulic stacker	1		
2	SDJAS operation manual	1		
3	Quality certificate	1		
4	Packing list	1		