

# **A-3028/A-3029/A-3030**

## Quick Start Guide

### FULLY ELECTRIC STACKER

Rated Load Capacity : 3,300lbs

Lifting Height: 118-220inch

Scan the QR Code for more information.



Thank you for choosing our full electric stacker.

For safe and correct use, please read this manual carefully and follow all instructions, precautions, and prohibitions. Keep this manual for future reference. Product specifications may change without notice. If there is any difference between this manual and the actual product, the product shall take precedence.

# TABLE OF CONTENTS

## INTRODUCETION

1. Warning
2. Parts Introduction
3. Installation Instruction
4. Inspection & Maintenance
5. Customer Support

# 1. WARNING

## ● Operating Environment

1. Operate this product only on hard, level surfaces.
2. Do not operate if the ambient temperature is above 104°F (40°C) or below -13°F (-25°C).
3. Do not operate at altitudes exceeding 1000 meters.
4. Do not operate in flammable, explosive, or corrosive environments.
5. Do not operate in rain or cold storage.

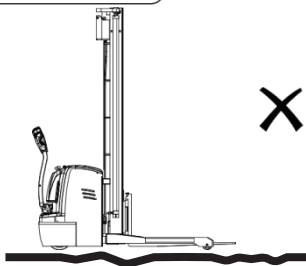
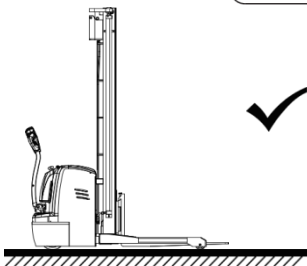

## ● Operational Guidelinest

### 1. Personnel Safety

- Do not carry passengers.
- Do not stand on or go under the forks.

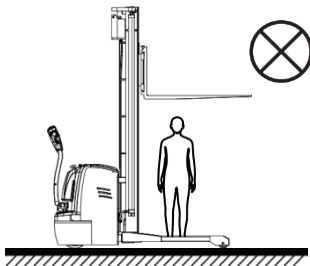
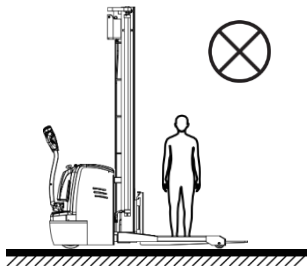

## 2. Load Limits

- Do not exceed the rated load capacity.
- Place loads securely in the center of the forks.
- Do not transport loose or unstable items.

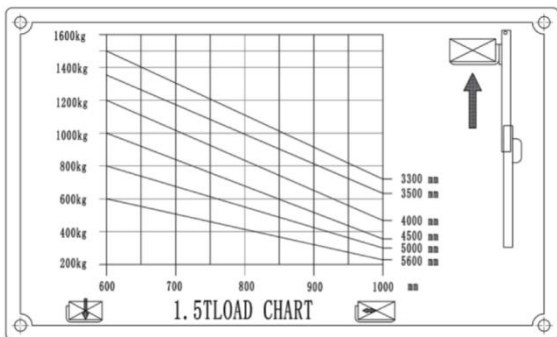
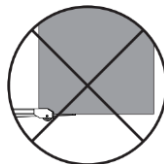
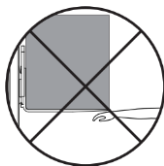
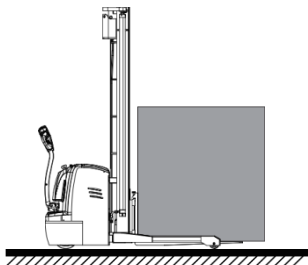

## ● Traveling and Lifting Guidelines

### 1. Starting and Traveling

- Wear safety shoes and ensure familiarity with all controls before starting the product.
- Pull the emergency stop switch and turn the key to the right.
- Sound the horn to alert nearby personnel before starting.
- Press handle down, Slowly rotate the forward/reverse rocker on the control handle to control the product's forward or backward speed and direction.

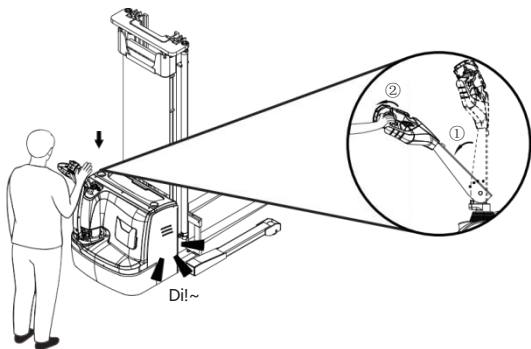

### 2. Braking

- Release the forward/reverse rocker. The product will automatically apply regenerative braking.
- Move the control handle to the vertical or horizontal position. The product will automatically engage electromagnetic braking.
- Press the emergency stop switch. The product will stop immediately.

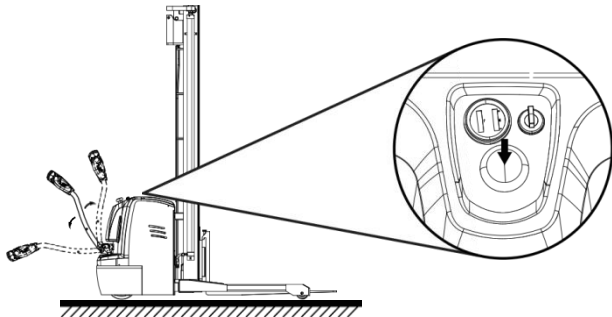

### 3. Lifting and Lowering

- Press the raise button on the control handle to lift the forks.
- Press the lower button on the control handle to lower the forks smoothly.

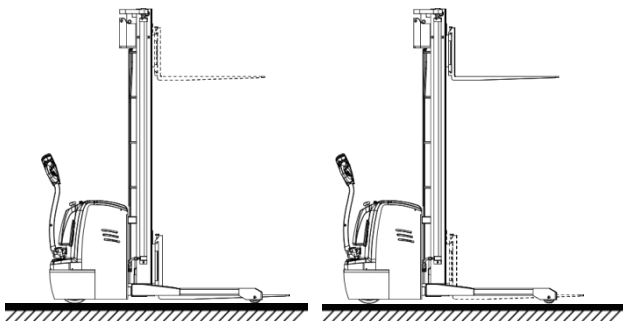
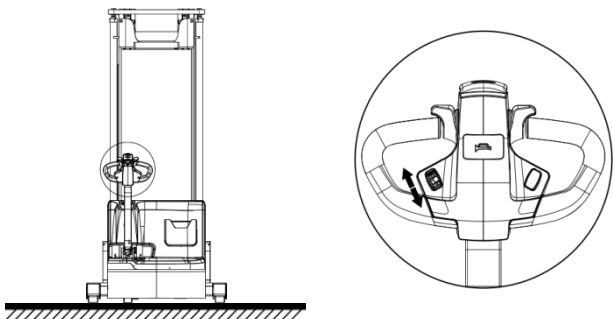

## 5. Ramp Operation

- When ascending with a load, keep the forks facing uphill.
- When descending, operate the product in reverse, keep the forks facing uphill, and control speed carefully.

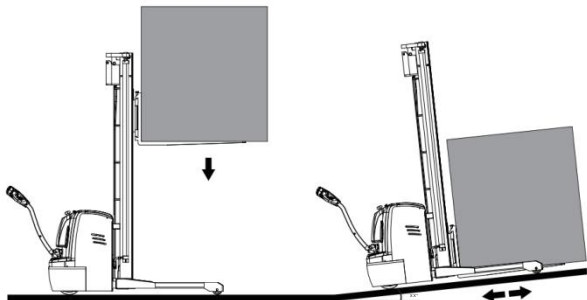

## 6. Charging

- Lower the forks, turn off the power, and remove the key.
- Open the battery compartment, disconnect the battery connector from the product, and connect the charger to the battery.
- If the product is unused for more than one month, charge the battery monthly to maintain its performance.

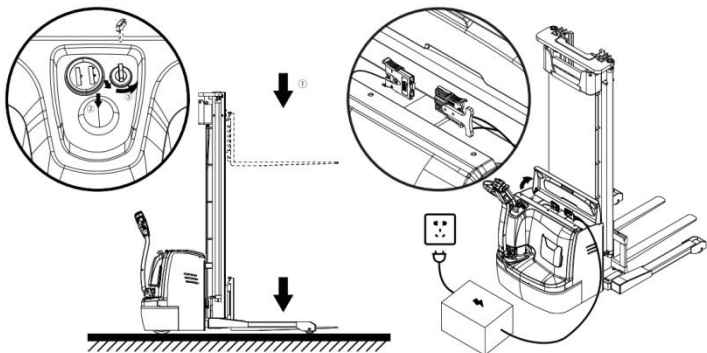

## 2. Parts Introduction

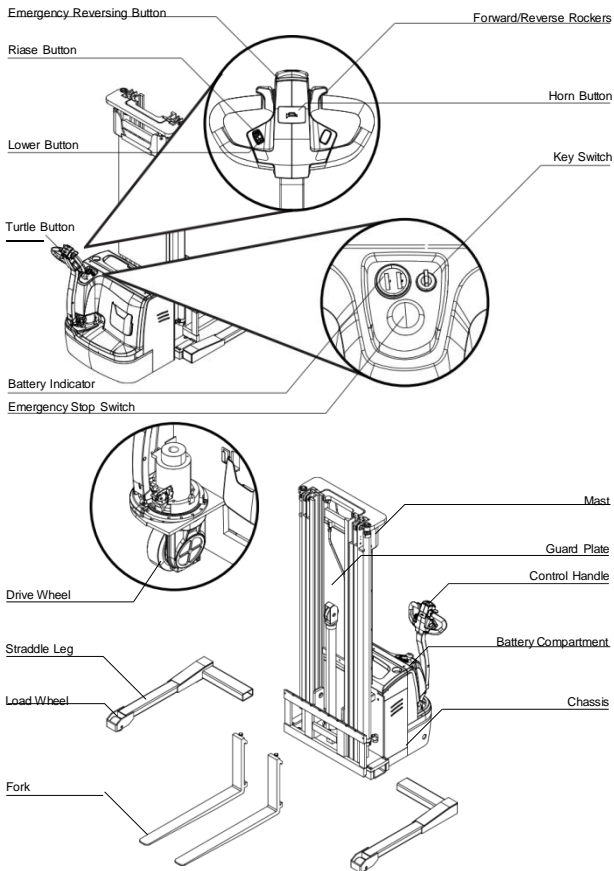

### 3. Installation Instruction

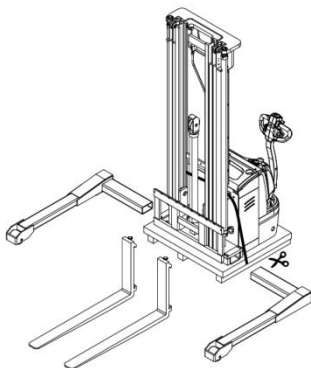

- ① Carefully unpack and check accessories (Charger, Manual, Handle)

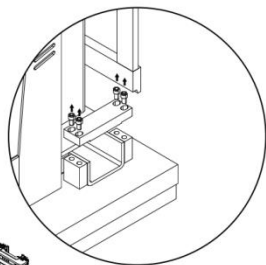

- ② Removing all securing straps. Remove the forks and legs

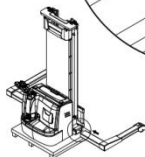
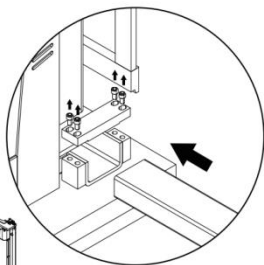

- ③ Install the legs and mounting plates, tightening the screws diagonally in sequence.

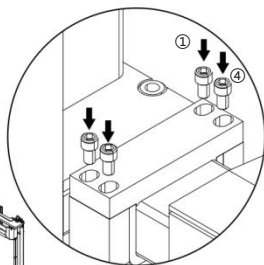

- ④ Install the legs and mounting plates, tightening the screws diagonally in sequence.

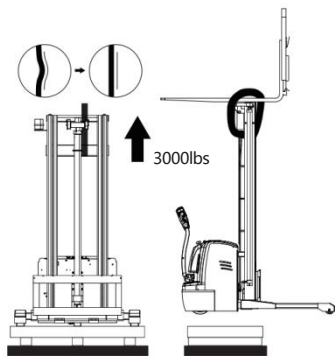

- 5 Lift & Land Use slings (rated >3000 lbs) through the mast crossbeam. Lift the unit with a hoist or forklift, remove the pallet, and lower the unit safely to the ground.

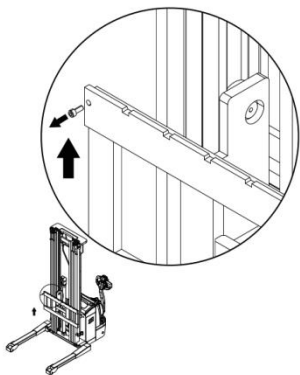

- 6 Once the stacker is stable on flat ground, re-tighten the screws on the straddle legs. Raise the fork carriage slightly (for easier access) and remove the Stop Screws on both sides of the carriage.

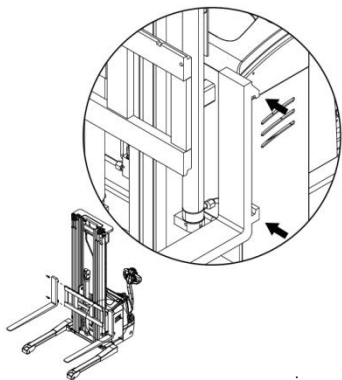

- 7 Slide the two forks onto the carriage from the sides and adjust them to the desired width.

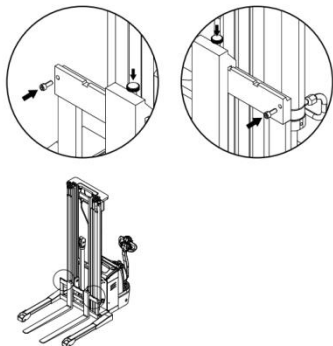

- 8 Engage the Locking Pins to set the fork position. Re-install and tighten the Anti-fall Screws on both sides to prevent the forks from sliding off.

Raise Button

Lower Button

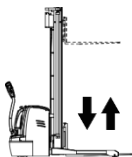
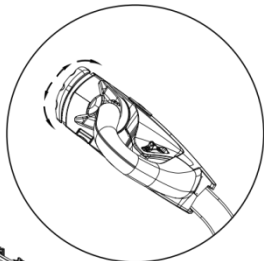
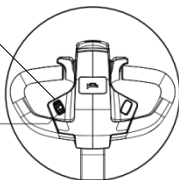

⑨ Test all functions: Throttle, Lift/Lower, Horn, Turtle Speed, and Tilt Forward/Backward

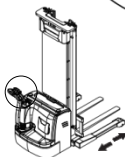

⑨ Test all functions: Throttle, Lift/Lower, Horn, Turtle Speed, and Tilt Forward/Backward

## 4. Inspection & Maintenance

Conducting a thorough inspection of the product can help prevent malfunctions and ensure it achieves its expected service life. Maintenance hours are based on 8 hours of operation per day, 200 hours per month. For safe operation, the product should be inspected and maintained according to the maintenance schedule.

### ● 200-Hour Inspection and Maintenance

No.	Component	Inspection or Service
1	Overall Condition	Check for abnormalities in moving, fork lifting/lowering, and forward/backward tilting.
2	Oil Pipe & Cylinder	Check for leakage.
3	Drive Wheel	Inspect for wear and debris entanglement; replace if functionality is impaired.
4	Load Wheel & Bearing	Inspect for wear and debris entanglement; replace if functionality is impaired.
5	Frame & Fastener	Inspect for cracks; check if all fasteners are secure.
6	Control Handle	Ensure all buttons function correctly and verify the brake operates effectively within the operational range.
7	Key Switch & Emergency Stop Switch	Ensure proper operation.
8	Brake	Clean dirt and dust from brake pads; check wear condition. Maintain brake gap between 0.2-0.8 mm.

### ● Maintenance Intervals for Consumables and Components

Component	Inspection or Service	Interval (hours)
Fork Wheel & Bearing	Replace	1,200
Drive Wheel	Replace	1,200
Seal	Replace	1,200
Gearbox	Change lubricant	1,000
Hydraulic Oil	Replace	1,000
High-Pressure Oil Pipe	Replace	2,000
Hydraulic Tank Filter	Clean	1,000
Drive Motor	Check functionality and bearing	1,000
Oil Pump Motor	Inspect brushes and bearings	1,000

## 5. Customer Support

- Warranty Period

1. **New Product (Complete Unit):**

1-year warranty from the date of receipt.

2. **Spare Parts:**

3-month warranty from the date of receipt.

3. **Battery:**

6-month warranty from the date of receipt.

4. **Used Product (Complete Unit):**

3-month warranty from the date of receipt.

- Warranty Coverage

Complete product and its accessories.

- Non-Warranty Items

1. Wearable parts, such as wheels under normal use and fuses.
2. Damage caused by improper or incorrect operation.

1. **Main Sales-after: [service@apolloliftus.com](mailto:service@apolloliftus.com)**

Main Customer Service: +1 888-801-3049

Working Hours: 9:00 AM to 5:30 PM