

CPD05W/CPD10W

Electric Counterbalance Stacker

- Operation Manual
- Parts Catalogue

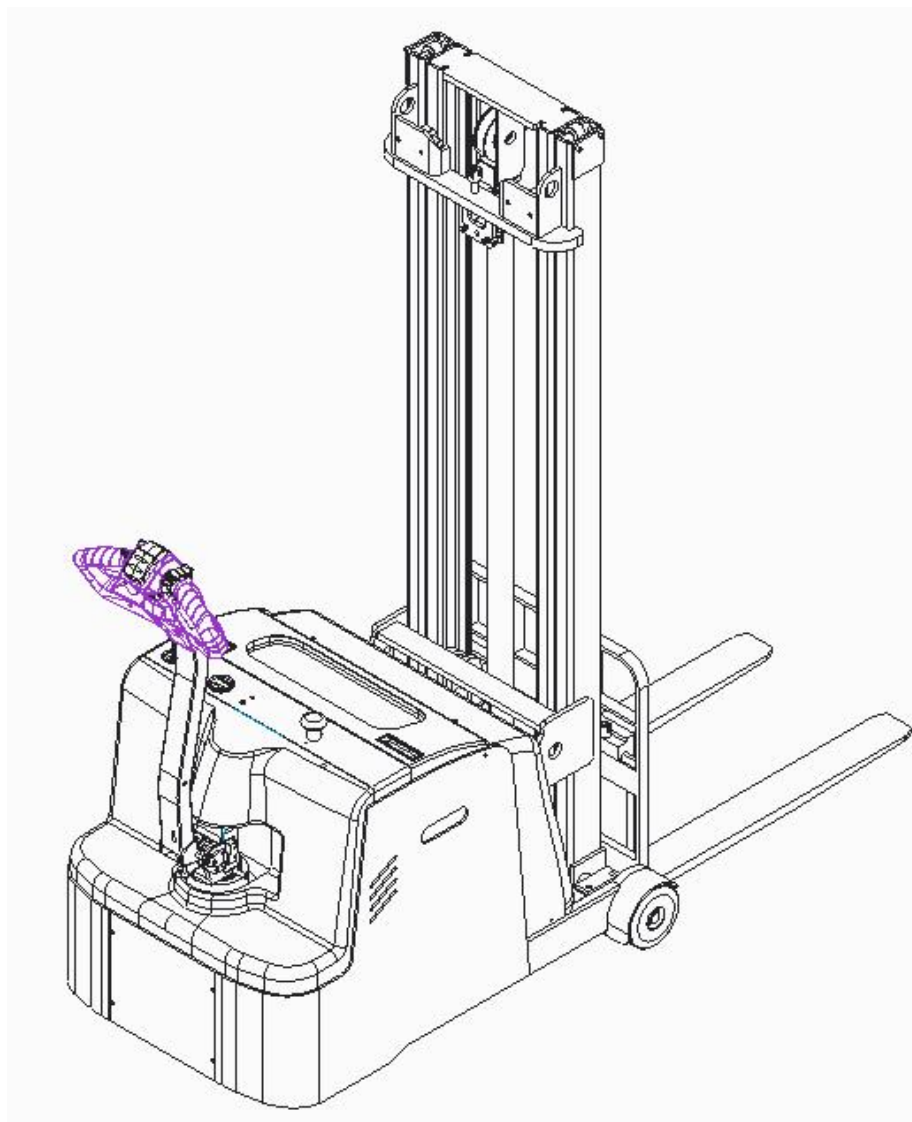

**Thanks for choosing our electric counterbalance stacker!**  
**Hope our electric stackers will bring great convenience to**  
**your work!**

- Please read the manual truckefully before operation.
- This manual is a common manual. We reserve the right to modify technology of the electric stacker. If there is anything in the manual that is not consistent with the actual stacker, the actual stacker should be considered correct and the manual is only for reference.

\*\*\*\*\*

## Warning!

- Operators must strictly conform to ISO3691 "Safety Specifications of Motor Industrial Trucks". Untrained personnel are not allowed to operate the stacker.

\*\*\*\*\*

According to ISO 3691 "Safety Specification of Motor Industrial Trucks", load capacity and lifting height of our CPD05W/CPD10W electric stacker are stipulated as follows:

— When the lifting height of CPD05W/CPD10W electric stacker is below 3000mm (including 3000mm), the maximum load capacity is the rated capacity. Overloading is prohibited

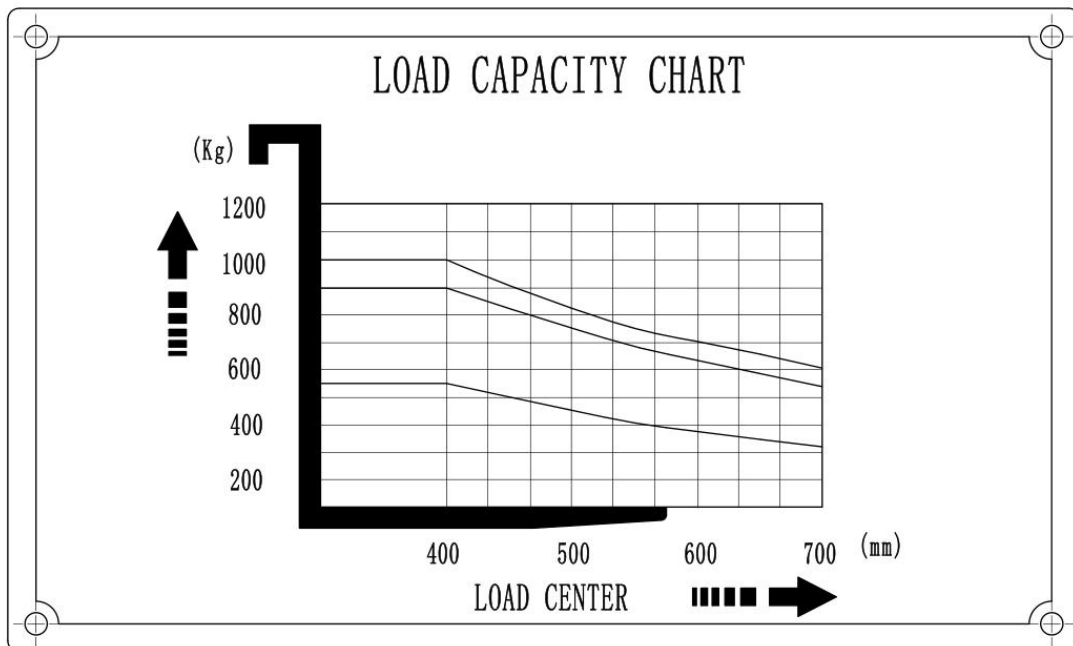

# Contents

<b>Brief introduction :</b> .....	1
<b>Description:</b> .....	1
<b>1. outline drawing</b> .....	2
<b>2. Brief introduction of structure</b> .....	5
<b>3. Safety Norms:</b> .....	5
<b>4. Initial operation</b> .....	10
<b>5. Use and operation instruction</b> .....	11
<b>6. Use, maintenance and charge of the storage batteries</b> .....	14
<b>7. Inspection before operation:</b> .....	18
<b>8. Inspection after operation:</b> .....	18
<b>9. Periodic maintenance and repair:</b> .....	19
<b>10. The store, transportation and loading of truck:</b> .....	23
<b>11. Replacement of storage battery</b> .....	24
<b>12. Common faults and trouble shooting:</b> .....	24
<b>13. Common fault signal and troubleshooting</b> .....	26
<b>14. Lists of accessories, spare parts and vulnerable parts</b> .....	28
<b>15. Structure diagram (explosion diagram) and principle diagram</b> .....	28
<b>16. Packing list</b> .....	32
Appendix 1 .....	33

## Brief introduction :

CPD05W/CPD10W electric counterbalance stacker adopts storage battery as power source, DC motor as power, and drives truck to walk through gear transmission. Lifting of the fork realizes by the DC motor and hydraulic drive to push oil cylinder to move up and down to lift fork and goods. It owns characteristics of labor saving, high efficiency, stable truckgo operation, simple operation, safe and reliable, low noise, no pollution,because the truck's walking and lifting are electric, the driving mode is walking, and the steering operation is rudder steering. The truck applies 24V battery, which greatly prolongs the use time after charge.

The truck is suitable for handling goods on hard and flat ground.

Allowed environment for using: :

- a. The altitude is not more than 1000 meters;
- b. Ambient temperature shall be lower than +40°C and higher than -25°C;
- c. When the ambient temperature reaches +40°C, the relative humidity should not exceed 50%; While at a lower temperature, higher relative humidity is allowed.
- d. Hard and flat ground
- e. It is prohibited to use the stacker in a flammable, explosive or corrosive environment with acid and alkali.

## Description:

The instruction manual shall be kept by the operator, and shall be carefully read

The instruction manual is composed of correct operation, convenient and simple maintenance, and routine inspection.

The instruction manual shall be truckefully read before operation, for purpose of correct drive and suitable maintenance to ensure safe and effective material transportation.



The instruction may be in disagreement with practical product due to product innovation.

The instruction manual shall be accompanied with in case of truck leasing or transfer.

Please come into contact with our sales department in case of any problem.

Description of symbol: Regulations of the following symbols are of great importance to your safety and others as well.

Please observe these regulations:

	Danger	Indicates an impending danger. Deaths or severe injuries would be resulted without any precaution or avoidance. You must observe those requirements.
	Warning	Indicates a potential danger. Deaths or severe injuries would be resulted without any precaution or avoidance. You must observe those requirements.
	Caution	Indicates a potential danger. Moderate injuries would be resulted without any precaution or avoidance. You must observe those requirements.
	Notice	You shall pay attention to statements that are in direct or indirect relation with personal security and truck maintenance.

# 1. outline drawing

## 1.1 CPD05W/CPD10W configuration diagram

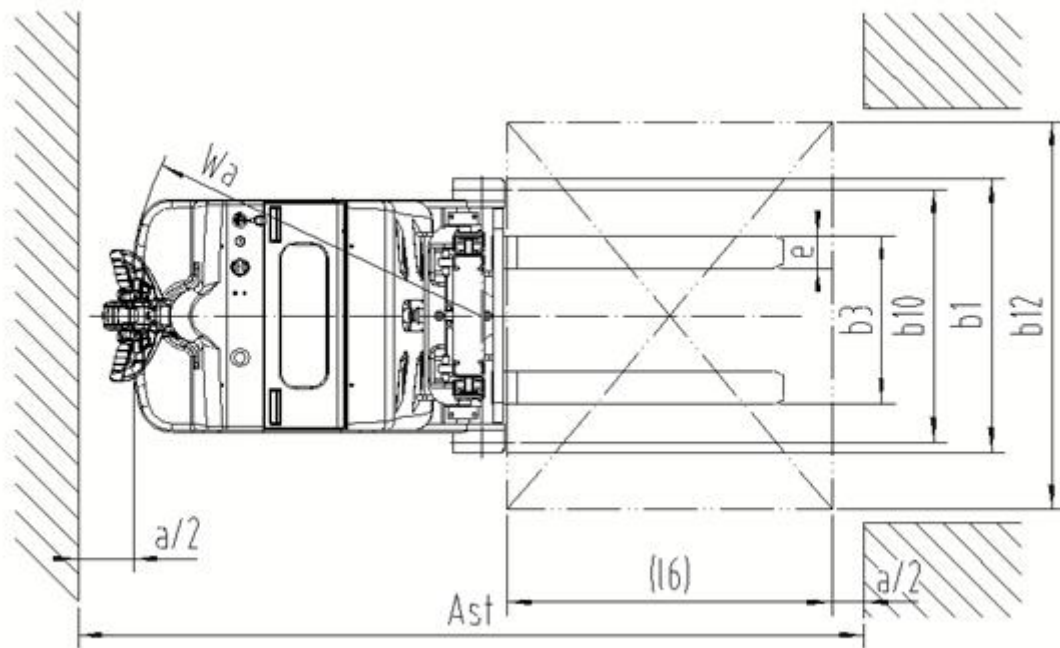
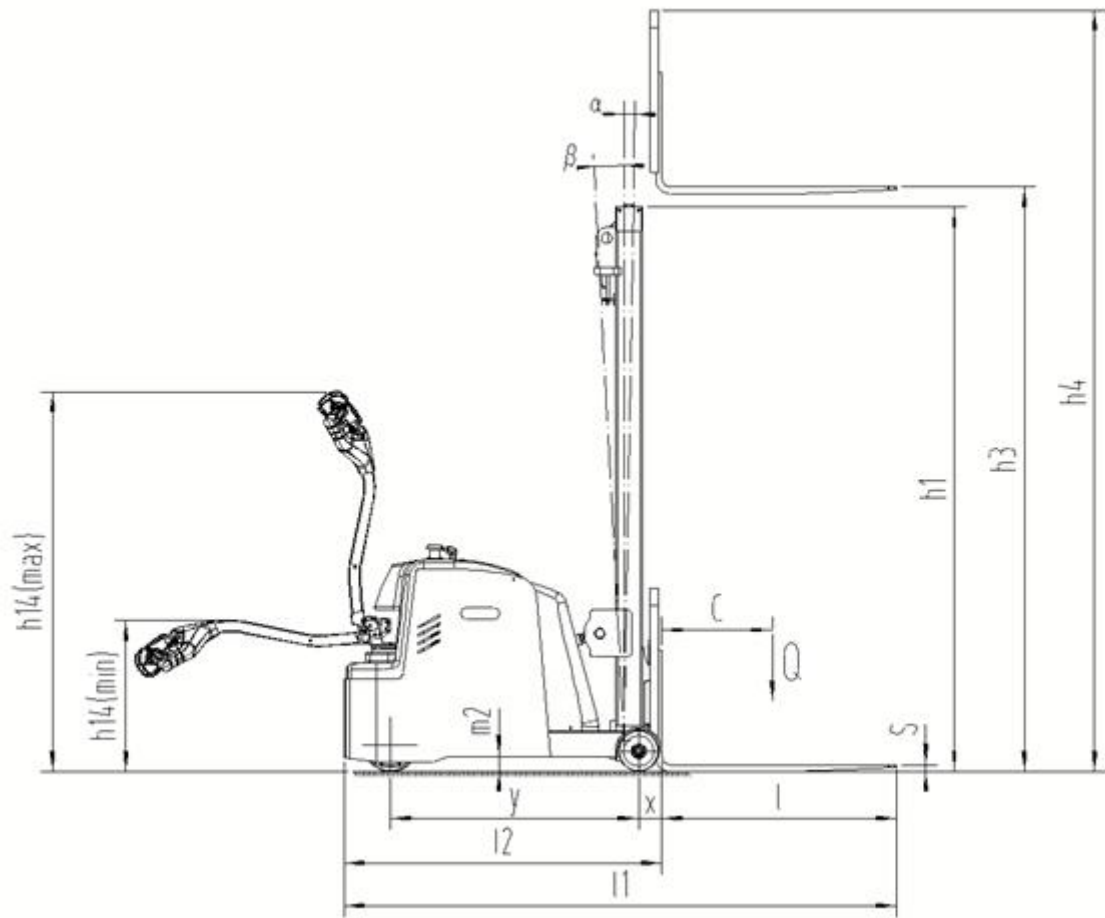

## 1.2 Main technical parameters

### CPD05W/ CPD10W electric counterbalance stacker

Characteristics	1.1	Manufacturer(abbreviated)			
	1.2	Model		CPD05W	CPD10W
	1.3	Driving model: Electric(Storage battery), diesel, gasoline, fuel gas		Electric	
	1.4	Driving model (Manual, Walking, Stand driving, Seat driving ,Order picking)		Walkie	
	1.5	Rated load	Q(kg)	550	1000
	1.6	Load center distance	c(mm)	400	
	1.8	Front overhang	x(mm)	90	
	1.9	Tread	Y(mm)	900	1150
	Weight	2.1	Service weight(with battery)	kg	875
2.2		Axle load, front/rear, laden	kg	1175/250	1856/324
2.3		Axle load, front/rear, unladen	kg	380/495	430/750
Wheel chassis	3.1	Wheels (rubber, high elasticity, pneumatic tyre, polyurethane wheel)		PU	
	3.2	Wheel dimension, front		Φ150×64	
	3.3	Wheel dimension, rear		Φ195×70	
	3.5	Additional wheel(dimension)		2/1X	
	3.6	Tread, front	$b_{10}$ (mm)	0	
	3.7	Tread, rear	$b_{11}$ (mm)	782	
	Dimension	4.1	Mast/front forward/backward	°	1/3
4.2		Height of mast, lowered	$h_1$ (mm)	2087/1552/1802/2052	
4.3		Free lifting height (optional)	$h_2$ (mm)	1400/0/0/0	
4.4		Lift height	$h_3$ (mm)	1600/2000/2500/3000	
4.5		Max. height of mast, extended	$h_4$ (mm)	2240/2640/3140/3640	
4.9		Min. /Max. height of operation handle	$h_{14}$ (mm)	670/1300	
4.19		Overall length	$l_1$ (mm)	2002	2356
4.20		Length to fork face	$l_2$ (mm)	1152	1406
4.21		Overall width of truck body	$b_1$ (mm)	846	
4.22		Fork dimension	s/e/l(mm)	32/100/850	32/100/950
4.25		Overall width of fork	$b_5$ (mm)	220-645	
4.32		Wheelbase ground distance	$m_2$ (mm)	55	
4.33		Aisle width, with pallet 1000x1200 crosswise	$A_{st}$ (mm)	2610	2770
4.34		Aisle width, with pallet 800x1200 lengthwise	$A_{st}$ (mm)	2750	2880
4.35		Turning radius	$W_a$ (mm)	1170	1334
Performance Data	5.1	Traveling speed, laden/unladen	km/h	4.1/4.5	3.8/4.2
	5.2	Lifting speed, laden/unladen	m/s	0.17/0.25	0.11/0.15
	5.3	Descending speed, laden/ unladen	m/s	0.14/0.14	0.85/0.9
	5.8	Max. gradeability, laden/unladen	%	6/10	5/10
	5.10	Traveling brake		Electromagnetic brake	
Motor	6.1	Driving motor power	kW	0.65(DC)	
	6.2	Lifting motor power	kW	2.2	
	6.4	Battery voltage/rated capacity	V/Ah	24/105	
	6.5	Battery weight	kg	60.8	
		Battery dimension (LXWXH)	mm	260X168X211	
	8.4	Noise level at operator's ear, according to DIN12053	dB(A)	65	

**CPD05W-Li/ CPD10W-Li electric counterbalance stacker**

Characteristics	1.1	Manufacturer(abbreviated)		
	1.2	Model		CPD05W-Li      CPD10W-Li
	1.3	Driving model: Electric(Storage battery), diesel, gasoline, fuel gas		Electric
	1.4	Driving model (Manual, Walking, Stand driving, Seat driving ,Order picking )		Walkie
	1.5	Rated load	Q(kg)	550      1000
	1.6	Load center distance	c(mm)	400
	1.8	Front overhang	x(mm)	90
	1.9	Tread	Y(mm)	900      1150
	Weight	2.1	Service weight(with battery)	kg
2.2		Axle load, front/rear, laden	kg	1175/250      1856/324
2.3		Axle load, front/rear, unladen	kg	380/495      430/750
Wheel chassis	3.1	Wheels (rubber, high elasticity, pneumatic tyre, polyurethane wheel)		PU
	3.2	Wheel dimension, front		Φ150×64
	3.3	Wheel dimension, rear		Φ195×70
	3.5	Additional wheel(dimension)		2/1X
	3.6	Tread, front	$b_{10}$ (mm)	0
	3.7	Tread, rear	$b_{11}$ (mm)	782
	Dimension	4.1	Mast/front forward/backward	°
4.2		Height of mast, lowered	$h_1$ (mm)	2087/1552/1802/2052
4.3		Free lifting height (optional)	$h_2$ (mm)	1400/0/0/0
4.4		Lift height	$h_3$ (mm)	1600/2000/2500/3000
4.5		Max. height of mast, extended	$h_4$ (mm)	2240/2640/3140/3640
4.9		Min. /Max. height of operation handle	$h_{14}$ (mm)	670/1300
4.19		Overall length	$l_1$ (mm)	2002      2356
4.20		Length to fork face	$l_2$ (mm)	1152      1406
4.21		Overall width of truck body	$b_1$ (mm)	846
4.22		Fork dimension	s/e/l(mm)	32/100/850      32/100/950
4.25		Overall width of fork	$b_5$ (mm)	220-645
4.32		Wheelbase ground distance	$m_2$ (mm)	55
4.33		Aisle width, with pallet 1000x1200 crosswise	$A_{st}$ (mm)	2610      2770
4.34		Aisle width, with pallet 800x1200 lengthwise	$A_{st}$ (mm)	2750      2880
4.35		Turning radius	$W_a$ (mm)	1170      1334
Performance Data	5.1	Traveling speed, laden/unladen	km/h	4.1/4.5      3.8/4.2
	5.2	Lifting speed, laden/unladen	m/s	0.17/0.25      0.11/0.15
	5.3	Descending speed, laden/ unladen	m/s	0.14/0.14      0.85/0.9
	5.8	Max. gradeability, laden/unladen	%	6/10      5/10
	5.10	Traveling brake		Electromagnetic brake
Motor	6.1	Driving motor power	kW	0.65(DC)
	6.2	Lifting motor power	kW	2.2
	6.4	Battery voltage/rated capacity	V/Ah	24/60(Allocation 100)
	6.5	Battery weight	kg	60.8
		Battery dimension (LXWXH)	mm	260X168X211
	8.4	Noise level at operator's ear, according to DIN12053	dB(A)	65

## 2. Brief introduction of structure (See also the structure diagram and the principle diagram of the major parts)

The stacker mainly consists of frame, mast, fork, lifting oil cylinder, operation handle, steering device, driving wheel, storage battery pack, hydraulic power unit and control system for electrical equipment, etc.

### 3. Safety Norms:



#### **Warning:**

Please pay attention to the following items first before operation of the truck:

- 1) This electric truck is only limited to utilization indoor with a hard flat floor. Operation in inflammable, explosive environment or corrosive environment such as acid or alkaline condition shall be strictly forbidden.
- 2) Only drivers who have received formal training or are authorized can be allowed to drive the truck.
- 3) Read this instruction truckefully before operation so as to master the performance of the stacker; check the truck whether it is in its normal condition before each operation. It is forbidden to use faulty stacker; repair by untrained persons is forbidden as well.
- 4) Overloading operation is forbidden.
- 5) As for goods truckrying and operation, center of gravity of the goods must be within range of the two forks. It is forbidden to transport loose goods
- 6) The truck shall travels slowly when forks pass in or out of pallet.
- 7) It is strictly forbidden to press the lifting or lowering button during the traveling of the truck. Meanwhile, don't switch lifting and lowering buttons rapidly or frequently, because rapid and frequent lifting or lowering will cause damage to the truck and goods.
- 8) Don't load heavy goods on the forks rapidly.
- 9) Don't lay the goods on the truck for a long time!
- 10) It is strictly forbidden to make sharp turn on narrow aisle. When it is turning, slow down the truck so as to ensure the safety of personnel and goods.
- 11) Descend the forks to the lowest position when the truck is not used.
- 12) It is strictly forbidden to put any part of the body under heavy goods and forks.
- 13) This truck is suitable to be used on flat ground or flat platform. Don't put the truck on the slope for a long time.
- 14) Overloading operation is forbidden. Otherwise the wheel will skid, resulting in the damage of wheel and motor as well as danger of the human body and goods.
- 15) It is strictly to use the truck under stipulated voltage of 20.4V.
- 16) It is strictly forbidden to conduct charge by connecting the plug to AC power directly.
- 17) It is forbidden to operate the stacker when the lift height of fork exceeds 500mm

### 3.1 Safety operation norms:

1) Training of driver:



#### Notice

Even though each electric pallet stacker may have the same technical parameters, there may be differences on features of braking and acceleration as well. Never drive the truck until you get familiar with all those operations.

2) Wear of the driver during truck driving:



#### Notice

Please put on safety shoes and protective clothes. Do not wear clothes that are too loose for sake of being caught, which would result in danger.

3) Rules that must be observed:



#### Notice

Never drive the truck when you are tired or un-concentrated, with an injection of drug, or after a liquor drinking.

Safety rules and regulations shall be observed during operation or maintenance of the truck.

4) Safety of working place:



#### Notice

This kind of electric stacker is only limited to utilization indoor with a hard flat floor. Operation in inflammable, explosive environment or corrosive environment such as acid or alkaline condition shall be strictly forbidden.

- A. Good roadway condition shall be kept and the traffic should be smooth.
  - B. Sufficient light ray shall be ensured on working place.
  - C. Fire extinguishing appliances shall be equipped in the places where truck and charging is operated. The extinguishing appliances shall comply with the requirements of extinguishing fire of solid combustible matter and electric apparatus.
  - D. The value of truck noise mentioned in instruction is measured under the condition of new truck running on flat, smooth and hard ground. If the traffic surface is bad or the tyre of truck is damaged, the noise may be amplified.
- 5) Integrity of the truck shall be realized:



#### Warning

Do not make modifications on the truck.

- A. Please observe safety rules and regulations of your working place during operation, inspection, and maintenance of the truck.
- B. Unauthorized truck modification is not permitted. No modifications or alterations to a powered industrial truck, which may affect, for example, capacity, stability or safety requirements of the truck, shall be made without the prior written approval of the original truck manufacturer, its authorized representative, or a successor thereof. This includes changes affecting, for example braking, steering, visibility and the addition of removable attachments. When the manufacturer or its successor approve a modification or alteration, they shall also make and approve appropriate changes to capacity plate, decals, tags and

operation and maintenance handbooks.

Only in the event that the truck manufacturer is no longer in business and there is no successor in the interest to the business, the user may arrange for a modification or alteration to a powered industrial truck, provided, however, that the user shall:

- a) arrange for the modification or alteration to be designed, tested and implemented by an engineer(s) expert in industrial trucks and their safety;
  - b) maintain a permanent record of the design, test(s) and implementation of the modification or alteration;
  - c) approve and make appropriate changes to the capacity plate(s), decals, tags and instruction handbook;
  - d) affix a permanent and readily visible label to the truck stating the manner in which the truck has been modified or altered together with the date of the modification or alteration, and the name and address of the organisation that accomplished the tasks.
- 6) Prepare safety operation procedure:  
Safety operation procedure shall be formulated with consideration of practical situations before operation of the truck. Safety shall be taken into full consideration in preparation of the safety operation procedure.
- 7) Operation of truck under unsafe condition is strictly forbidden:
- A. Operation under unsafe condition is forbidden, such as under conditions with uneven floor, or impeded road. Goods lifting on slope is strictly forbidden.
  - B. Faulty truck is forbidden to use.
  - C. Make sure a daily inspection of the truck would be taken. Please immediately repair or replace in case of any abnormal conditions.
- 8) Overloading operation of truck is forbidden:



### Warning

Overloading operation of truck is forbidden. Overloading operation would cause damage to the truck or bring harm to operator.

- 9) Use suitable pallet:  
The pallet shall be of suitable dimensions, neither too wide nor too large.
- 10) Electrical system check:



### Notice

Before checking the electrical system, turn off the key switches and the emergency isolation switches.

## 3. 2 Safety Operation Specification:

- 1) Check the safety condition around the truck:



### Notice

Before starting up the truck, please ensure that there is no person around it.



### Notice

If the driver's view is shielded by the bulky goods truckried, please drive backwards or drive under the guidance of other working personnel.



### Notice

Ensure no people around the truck when driving backwards.



### Notice

Driving through the narrow access shall be guided by working personnel.



### Notice

At crossroad or other places impeditive for view, the driver shall not drive until there is no person at both sides.



### Notice

Keep concentration when operating truck.



### Caution

The driving mechanism of truck is installed on the foreside. Due to this difference from common trucks, the foreside of truck swings comparatively fast when turning around. For this reason, to prevent collision with other objects nearby the foreside of truck, do drive or turn slowly.

## 2) Strictly forbid harsh driving



### Notice

Never start up, brake or turn abruptly.

Abrupt start-up or braking may cause the falling of goods. Abrupt turning during traveling may cause the tilting of truck and result in serious accident. Do decelerate and take truck to turn.



### Notice

Observe all items of safety rules on working place. Decelerate and sound horn when travel by other truck or trucks. Avoid driving in places with bad view.



### Notice

Ensure to provide certain clearance between truck and entrance.

3) Never drive too close to roadside:



**Notice**

Ensure to provide enough distance between the truck and roadside or platform edge.

When running on narrow road or platform, keep a certain safety distance with the edge against falling of the truck.



**Warning**

Avoid turning or loading and unloading operation on slope; otherwise the truck can go tilting.

**3. 3 Operation norms:**



**Notice**

The truck can only truckry goods under rated capacity.

- 1) Forbid overloading operation.
- 2) Forbid deflective transportation.
- 3) Passengers on truck must be forbidden.
- 4) Never push or pull the handle abruptly
- 5) Never use the truck as towing truck.
- 6) When transporting over-wide goods, the driver shall be extremely truckeful to turn slowly to keep balance of the goods. Decelerate when ascent and descent, meanwhile, watch around for sake of safety.
- 7) The faulty truck for future repair must not be parked at places impeditive for traffic. Lower down the fork arms to the lowest position and put on the warning board. Pull off the key.
- 8) When protective devices suck as protective cover of mast is not mounted, it is forbidden to operate the truck.
- 9) Take trucke to avoid the danger of wind force when loading goods.



**Notice**

Take truck to avoid the danger of wind force when loading goods.

- 10) The operator shall master the traveling speed according to site condition. The truck shall slow down and move at a low speed when turning, at a narrow aisle, passing by swing doors or places where view impeded. And the truck shall keep enough distance with the forklift moving forward. Abrupt stop, sharp turn and overtaking are forbidden at dangerous places or where view is impeded except accidents. It is forbidden hold body or hands out of the driving cabin.
- 11) Driver's view during operation: The driver's view must keep in the traveling direction of the stacker and pay attention to the condition on driving roads at all times. If the goods truckried impeding driver's view, goods truckried must be adjusted to the backward of driver's view. If the goods can not be adjusted, another operator shall be arranged and walk by the stacker so as to report the forward road condition for the truck driver.
- 12) Upgrade or downgrade driving: The route of upgrade and downgrade shall be specified driving roads. The ground shall be kept clean, safe and reliable in accordance with technical performance of the stacker. When the truck is moving upgrade with goods, the forks should be kept in the forward position. While

driving downgrade, the stacker shall move backward. Turning, tilting driving and parking is not allowed during upgrade and downgrade moving. Make sure to slow down when downgrade driving and always make prepare for braking.

- 13) Driving the stacker to elevator or charging platform: When it is necessary to drive the stacker to elevator or charging platform, make sure that elevator or charging platform has enough loading capacity, with the design structure applicable for bearing stacker. Meanwhile the elevator and charging platform should be permitted by the equipment user. Checks must be truckried out before operation. Before driving into the elevator, the goods should be truckried into the elevator first and select the suitable parking space for the truck in order to avoid collision with walls during lifting. When there is other person needs to use the elevator, they should place the stacker at first. Then they can come into the elevator afterwards. When the elevator reaches the specified height, the personnel shall get out of the elevator at first.
- 14) Conditions for goods to be transported: The stackor operator should checke the goods truckefully make sure that there is not any risk. Before transportation of the goods, place and locate the goods. If there is any possibility of falling or overturning of the goods during transportation, it should be mounted with protective devices (such as protective guard).

### **3. 4 Important notice after operation:**

- 1) Parking: Park the truck at appointed place. Never park the truck on slope.

Ensure the following points to be achieved before leaving away the truck:

- a. Lay down the fork to the lowest position naturally.
- b. Turn the steering wheel to the middle position.
- c. Turn off the key switch.

- 2) Clean up the truck:



#### **Notice**

When cleaning up the electrical system, use compressed air but not water.

- 3) Charge:



#### **Warning**

Open flame is forbidden to appear at the charge places, otherwise, explosion or fire disaster can be caused.

Make a record of charge. As for the charge method, refer to the part about storage battery operation:

## **4. Initial operation**

### **4.1 Initial operation:**

- 4.1.1 In case of dangerous conditions, the power can be cut off, and the battery plug must be connected to the emergency parking plug of the stacker itself.



#### **Warning**

It is strictly forbiddent to operate the stacker without emergency parking plug.

- 4.1.2 The stacker can only be driven by the battery power, but without rectified AC current which may damage the electric parts of the truck. And length of battery cable (tow cable) shall not be over 6m.
- 4.1.3 If the stacker is driven by the external battery through a tow cable, it is forbidden to lift the loads.
- 4.1.4 Befor initial operation of the stacker, checks must be truckried out as follows:
  - a) Check that whether the device is complete or whether the status is normal.

- b) If the stacker has not been mounted with battery, it must be mounted with battery. Take truck not to damage the battery cable.

4.1.5 The feature curve of charger shall be adjusted (charging curve) .

4.1.6 If the truck is not used for a long time, wheels placed on the ground will be pressed. Only after the truck is put into operation for a short time, the wheel can come to the original shape.

#### 4. 2 Drive of the stacker without the driver of the stacker itself:



### Warning

It is strictly forbidden to drag the stacker on the slope.

4.2.1 In case of dragging stacker during emergency operation, the electromagnetic brake must be loosened.

4.2.2 When the stacker is placed at a specified place, the electromagnetic brake must be relocated so as to make the stacker in a state of brake

## 5. Use and operation instruction

The electric pallet stacker adopts storage batteries as the dynamic source for short distance goods handling and stacking. Correct use and operation will bring great convenience to your work but incorrect use and operation will damage the stacker or pose risk to you and your goods.

### 5. 1 Before operation:



### Warning

It is strictly forbidden to use faulty truck.

5.1.1 Before operation, please check if the truck is in normal condition: Is there any oil leakage in the hydraulic pipes? Are the supporting wheels able to operate normally? Is there any block? The trucks with problems are prohibited for operation.

5.1.2 Check if there is any electric power in the batteries with the method indicated in Fig.I. Pull the general power switch out to turn on the general power supply, unlock the electric lock on the handle, check the electric energy meter on the instrument panel of the truck. If the zero end grid is bright, it indicates there is no electric power in the batteries and charging should be conducted at once. It is prohibited to operate the truck without electric power as that will greatly reduce the service life of the batteries and even damage the batteries.

### Battery has no electricity when the grid lights up

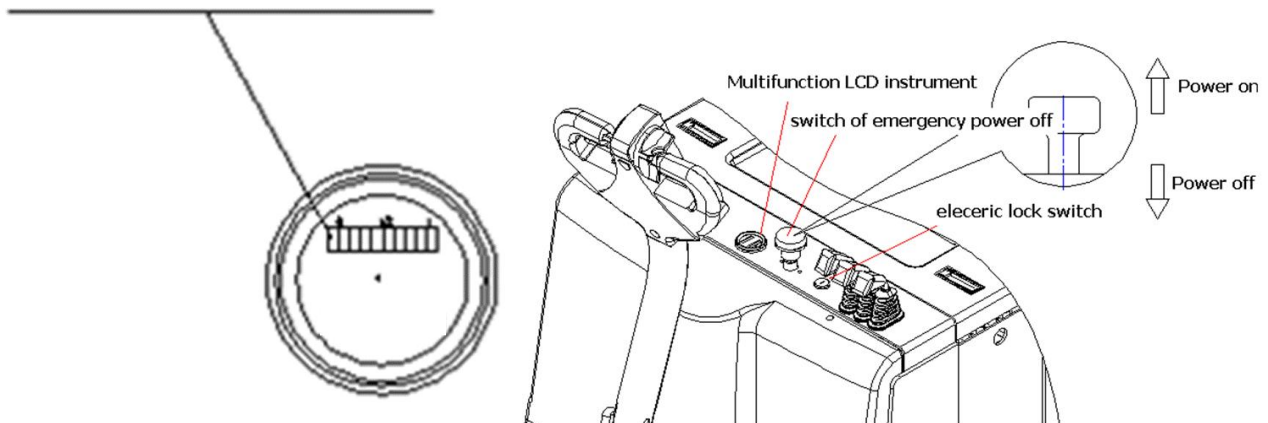

Fig.1

5.1.3 Check if the truck brake is normal. Check the lifting, dropping, forward and backward traveling of the truck to see if the actions are normal. Check if the emergency reverse action of the truck is normal with the method indicated in Fig.II:

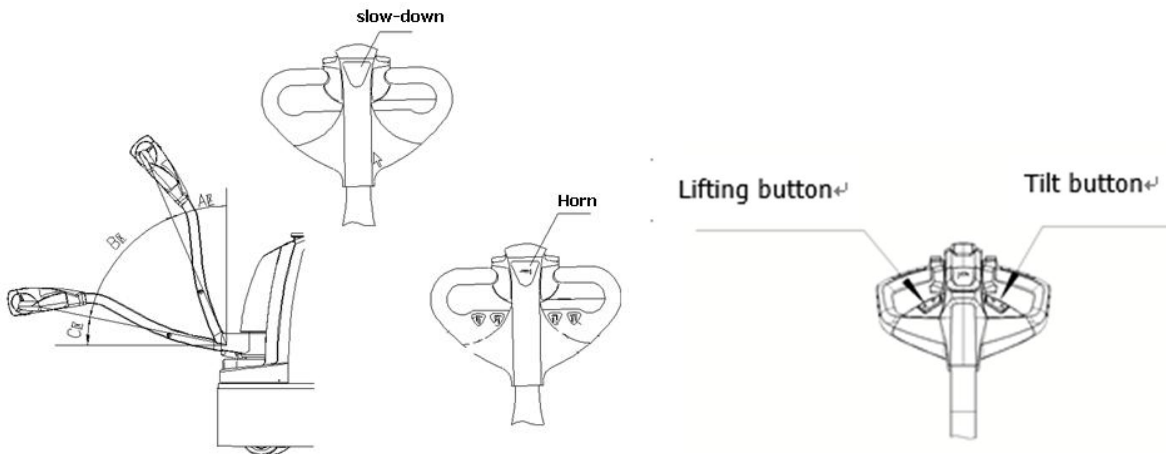

Fig.2



### Warning

It is strictly forbidden to turn the accelerator knob fastly to speed up the stacker abruptly during goods transportation.

Press handle to either section A or section C, as shown in Fig. 2, to break the truck.

Press the handle to section B, as shown in Fig.2, to make the truck travel slowly; check whether the truck is able to travel normally by pressing the handle until it is horizontal.

Press the handle to section B, as shown in Fig.2, and press the emergency reversing button at top of the handle to make the truck travel in the opposite direction.

Inspect whether the truck is in a good condition by operations mentioned above. If there is any fault found over the inspection, please settle the problem as soon as possible. Trucks with any fault are prohibited to use.

### 5.2 In operation:

5.2.1 Accelerator knob: The accelerator knob is used for controlling traveling direction and speed of the stacker.

When it is for the traveling operation, turn the operation handle to B area indicated in the above diagram.

When the handle is in A or C area, the stacker is in a power-off status, and can not travel. When the operation handle is in B area and the accelerator knob is turned in one direction, the stacker will travel in that direction. While the accelerator is turned in another direction, the stacker will travel in another direction. Meanwhile the bigger the turning amplitude is, the faster the truck will travel.

Note: A side-magnetic brake is installed on the shaft end of the driving wheel motor and there is a cam and an inching switch installed on the rotary shaft of the rotary arm. Only when the rotary arm is at  $30^{\circ} \pm 20^{\circ}$  (as indicated in Fig. II), the stacker can be turned on and travel. Larger or less than the angle, the stacker will be powered-off and braked. In that case, the stacker can lift goods. When lifting goods, the stacker cannot travel. As indicated in Fig. II, when the operation handle is in division A or division C, the stacker can only lift or lower but not travel; when the control handle is in division B, the stacker can travel as well as lift or lower. The operation position of the handle will not be specially described in the following descriptions, i.e. the stacker can only lift or lower but not travel when the handle is in division A or C and the handle must be in division B when the stacker is traveling.

5.2.2 As indicated in Fig. II, there is a button on the operation handle which is used for slowing down the stacker. When this "slow down" button is pressed as well as accelerate knob is turned, the stacker will travel at a low speed. This state is best suitable for turning a corner, stacking and moving into and out of

the shelf while taking goods. When the "slow down" button is released and the accelerate knob is turned, the stacker will travel at a normal speed.

#### 5.2.3 Safety height:

The safety lift height for mast is about 1.8m (according to the assembled mast): If the mast is lifted to a height which is over the safety height, the stacker will slow down to about 3km/h

#### 5.2.4 Operation of handling and stacking:



### Notice

Please check the following items before operation of the stacker:  
Ensure no goods falling and goods damaged at loading and unloading area.  
Ensure no goods or objects impeding for safety.

As indicated in Fig. II, pull out the general power supply switch, unlock the electric door lock, and drive the stacker to the goods pile nearby. (The tip of the fork is 300mm from the goods pile). Press the lowering button, adjust the height of the fork to a proper position, and insert the fork slowly and as deep as possible into the pallet of the goods. Press the lifting button till the fork is 200-300mm from the ground. Drive the stacker to the location of the goods shelf and stop slowly. (The tip of the fork is 300mm from the goods shelf.) Press the lifting button and the fork rises to a proper height with the shelf (The bottom of the pallet is about 100mm higher than the goods shelf). Move the goods slowly to the accurate position of the shelf and press the lowering button to put the goods truckefully on the shelf. Take the fork away from the goods and drive the stacker slowly to make the fork out of the goods pallet. (The tip of the fork is 300mm from the goods shelf.) Lower the fork until it is 300mm from the ground and drive the stacker away from the shelf. Attention should be paid to that there should be no obstacles around and when turning, the speed should be reduced



### Caution

The driving mechanism of truck is installed on the foreside. Due to this difference from common trucks, the foreside of truck swings comparatively fast when turning around. For this reason, to prevent collision with other objects nearby the foreside of truck, do drive or turn slowly.

#### 5.2.5 Operation of taking goods off the goods shelves:

As indicated in Fig. II, pull out the general power supply switch, unlock the electric door lock, and drive the stacker to the goods shelf nearby. (The tip of the fork is 300mm from the goods shelf). Press the lowering button, adjust the height of the fork to a proper position, and insert the fork slowly and as deep as possible into the pallet of the goods. Press the lifting button to lift the goods till the bottom of the pallet is 100mm from the goods shelf. Slowly drive the stacker and slowly move the goods out of the shelf (the tip of the fork is 300mm from the goods shelf). Press the lowering button and the fork lowers to a height of 200-300mm from the ground. Drive the stacker away from the goods shelf until it reaches a desired position and then slowly stop it. Press the lowering button to put down the goods, make the fork completely away from the goods and move the fork slowly out of the goods pallet.

### 5.3 Abnormal situation handling during operation:

#### 5.3.1 When pressing the lifting button, the fork can rise but when releasing the lifting button, the fork is still rising.

The stacker is in a situation of out of lifting control. In that case, turn off the general power supply switch to cut off the power supply at once. Drive the stacker to a safe position to lower the fork manually and repair the circuit of the stacker.

#### 5.3.2 If the brake is out of function when the stacker is in operation, the operation must be stopped at once and repair the stacker.

#### 5.3.3 When the stacker is moving forward and pushing the operator against a wall or other objects, press the

emergency reverse button on top of the operation handle and the stacker will automatically move backward to avoid injuring the operator.

#### **5.4 After operation:**

After operation, the stacker should be parked in a fixed parking position and routine maintenance should be conducted according to the stipulations in clause 6 and charging should be truckried out.

## **6. Use, maintenance and charge of the storage batteries**

### **Charging method:**

Either on-board charger or external charger is optional.

**On-board charger:** Charging starts several seconds after connecting the plug to the 2-phase AC power supply.

**External charger:** Charging starts seconds after connecting the connectors of the charger and the truck together, then insert the charger plug into a 2-phase AC power supply.



### **Warning**

There is hydrogen gas accumulated in the battery case during charging. Thus the charging environment requires good ventilation and there should be no flame, otherwise explosion or fire may occur.

### **6.1 Initial charge**

6.1.1 Initial charge should be conducted for batteries that have never been used

### **6.2 Use and maintenance**

6.2.1 In order to guarantee the service life of the batteries, the batteries in use should be fully charged.

Insufficiently charged batteries must not be used. During the process of use, close attention should be paid to the discharge extent. Over discharge is prohibited.

6.2.2 The batteries in normal use should avoid over-charge, but over-charge must be properly conducted for the batteries in following situations, i.e. equalizing charge.

- a. The "lag-behind" batteries--- batteries with a voltage lower than that of the other batteries in the discharging process and the batteries having been repaired for failure. (When equalizing charge is conducted, the positive and negative poles of the "lag-behind" battery should be respectively connected with the positive and negative ends of the charger, the DC power supply, and the charge should be conducted independently.)
- b. Equalizing charge should be conducted for the batteries in normal use every 2-3 months.
- c. Equalizing charge should be conducted for the batteries that have not been used for a long period of time before use.

### **6.3 Storage**

Batteries should be stored in a clean, dry and well ventilated warehouse with a temperature of 5-40°C. The valid shelf life is 2 years. The batteries should be kept according to the following requirements during storage:

- a. No direct sunshine on the batteries and at least 2m away from heat source.
- b. Avoid contacting with any harmful substances. No metallic matters are allowed to drop into the batteries.
- c. The batteries should not be placed upright down and should not be impacted mechanically or heavily compressed.
- d. The batteries must not be stored with electrolytic solution. When it is required in special situation that the batteries must be stored with electrolytic solution, the batteries should be fully charged and the

density and the liquid surface of the electrolytic solution should be adjusted to the stipulated values. When the storage period comes to one month, the batteries should be complementarily charged with the common charge method.

#### 6.4 Charger

If the charger you use is full automatic type. It must meet with the following 2 requirements:

- a. The output voltage of charger: 24V
- b. The output current of charger (storage battery) : 10A
- c. The output current of charger (Li-ion batteries) : 25A

#### 6.5 User Requirements for the Secondary On-board Li-ion Battery System

This URD (user requirement document) is generally applied into the usage , maintenance and any other operations occur to the Li-ion batteries (Secondary On-board Li-ion Batteries System) on both electric storage and logistic vehicles .

##### 6.5.1 Requirements on operators

- (1) Relevant people who are able to use, maintain and take any actions to Li-ion batteries on all electric storage and logistic vehicles (hereinafter referred to as operators).
- (2) Any operators are only allowed to operate the Li-ion batteries under the backgrounds of professional training , acquiring certain knowledge of Li-ion batteries, and obtaining certifications from relevant departments.

##### 6.5.2 Safety Regulation

- (1) These signs shown below might be found either on the Li-ion battery cases or on the vehicles, which are set on considerations of the safeties of the batteries as well as the operators. All the operations must be under the guidance of them.



#### High Voltage Warning:

It indicates a possible danger of lightning shock. All the electric work of the equipment must be finished only by qualified professional workers. Unauthorized disassembly is prohibited



#### Corrosive Risk Sign:

It indicates to pay attention to protect the products when unsafe factors exist over the production.



#### Waterproof & Humidity proof Sign:

It indicates to protect the products from rain, water and humidity.



#### No Fire Sign:

It indicates that fire is prohibited in this area when the product is on.



#### Do Not Step Sign:

It indicates the products must not be stepped on.

- (2) The use of Li-ion battery vehicles shall be in accordance with the requirements of temperature, humidity and environment specified in the vehicle instructions, and the maintenance and disassembly of lithium battery shall be carried out when the battery case is clear without any foreign bodies, especially metal tools, and there are no impurities or blockages in the air duct.
- (3) Operators are forbidden to short-circuit connect lithium batteries, otherwise the system will be seriously

damaged and people will be injured.

- (4) Li-ion batteries should be kept away from heat , fire and avoid long time direct sunlight. Li-ion batteries must not be placed in liquid (such as water, solvent) or high humid environment to avoid damages caused by leakage or short circuit.
- (5) Installation, commissioning and maintenance of lithium batteries in rain and snow weather should be carried out indoors to prevent short circuit caused by rainwater entering Li-ion battery system.
- (6) Because of the communication protocol between the management of lithium batteries and vehicles, it is prohibited to interchange lithium batteries with the same voltage and capacity on different vehicles without the permission of the host plant.
- (7) It is forbidden to mix Li-ion batteries with other batteries in one vehicle. For the vehicle that is about to replace batteries, it is necessary to check up whether the new batteries are with the same model and with the same group or not before restart it.
- (8) The Li-ion battery cases shall be transported and moved strictly in accordance with the regulations without any improper operations like towing, prying and kicking, which will cause mechanical impact on the batteries, such as dropping, impacting and pressing. It's highly prohibited to overlap, upside down and side-up lithium battery cases.
- (9) It is necessary to ensure the correct connection and normal operation of the lithium battery management system whether charging or discharging, and to ensure the normal communication between the lithium battery management system and the vehicle system.
- (10) Li-ion batteries are prohibited to contact and to be placed together with objects that will possibly cause a short circuit. Sharp stuff and workers in clothes and accessories with metal are not permitted to get close to Li-ion batteries.
- (11) Periodically check the lithium battery information displayed by vehicle meters. If there is any problem, do not open and operate the battery case by yourself. Contact relevant technical personnel immediately for further guidance.
- (12) Unauthorized disassembly, damage and installation of lithium battery components are strictly prohibited. It is forbidden to dissect lithium batteries or lithium battery groups without authorization in order to avoid danger. Non-professional workers are forbidden to replace the data transmission interface and voltage acquisition interface of lithium battery management system to prevent short-circuit damages to system components and even cause fire. Safety warning signs must be obeyed for safety<sup>s</sup> sake.
- (13) If operators find any of the following situations or have any concerns about the safety of the product, shut down the vehicle first, and take measures like disconnecting the power connection to ensure the safety of both the operators and the vehicle, then immediately contact the relevant personnel for further guidance. Solutions provided as follow:
  - a) Contact relevant technicians for emergency repair when see the signs of overheating, smoking, and sparking; battery pack damage (such as rupture), battery leakage; battery system case and power cord take in water.
  - b) Contact relevant technicians for an overhaul when see ruptures or damages of the power cord, plug, extension cord, protective device; or when confronted with the problems that don't threat personal or vehicles'safety , like the vehicle fails to work normally.

### 6.5.3 Requirements on Charging the Li-ion batteries

- (1) The charging temperature range is 0-50°C. Li-ion batteries are not allowed to charge in the environment below 0°C except those with heating system. Low-temperature charging will cause lithium evolution and affect the service life of Li-ion batteries.
- (2) The charging place should keep clean and well ventilated, and always keep away from inflammable and explosive articles. Fireworks are strictly prohibited in the charging area.

- (3) Operators are suggested to help themselves to charge only with the certain charging equipment coming with the vehicle from the manufacture to maximize the safety performance of Li-ion batteries. Make sure to connect the positive and negative poles correctly and never do reverse charging.
- (4) After the battery is fully charged, unplug the charging line in time to avoid other safety problems.
- (5) Abnormal termination of charging may occur during the charging process of lithium batteries. For example, if the charging voltage is too high or the charging current is too large. The phenomenon is defined as "Abnormal Termination of Charging". When it occurs, it may indicate the leakage of lithium batteries or failure of some parts. It is necessary to notify relevant technicians for a complete inspection, finding out the causes and solving them before resuming the charge.

#### 6.5.4 Requirements on discharging the Li-ion batteries

- (1) Discharge temperature range is -20-60°C.
- (2) When a lithium battery fault is found in display during the start-up or operation of a vehicle, the cause of the fault should be inquired according to the display code and the schedule of the vehicle instruction, and the technical personnel should be notified to deal with it in time.
- (3) It is necessary to ensure that lithium batteries are not less than 50% charged before maintenance or repair.
- (4) To prevent damages of lithium batteries caused by over discharge, it is necessary to charge lithium batteries in time when the instrument displays low charge alarm.

#### 6.5.5 Requirement on transportation and unloading

- (1) Firm out packages are highly required when Li-ion batteries are about to transport.
- (2) Sign of water proof, sign of humidity, sign of upward, sign of careful and light handling shall be attached to the out packages. In case of being damaged, the battery cases must be placed upward according to the sign.
- (3) When the lithium batteries are dislocated or extruded during transportation, the exposed wiring harness and connectors should be checked to see if the lithium batteries are damaged or deformed. In case of smoke, sparking, stay away from the scene immediately, and professional technicians should be notified.

#### 6.5.6 Requirements on the storage

- (1) The storage of lithium batteries should be in clean and ventilated rooms with ambient temperature ranging from - 10 ~35 °C (recommended storage temperature ranging from 0 ~25°C). Long-term storage batteries (more than 3 months) should be placed in an environment with temperature of 25 ±3 °C) and relative humidity of 65 (±20%).
- (2) The contact between lithium battery and corrosive chemicals or gases shall be avoided, so as to prevent the corrosion of lithium battery or its connecting parts, affecting the appearance and service life of the battery.
- (3) Keep Lithium batteries away from fire and heat, meanwhile, keep the batteries dry.
- (4) Insulation, waterproof and dustproof are required over the storage. Make sure that the protective cover plate above the lithium battery case is fixed tightly without defects and damages. The battery case should be covered with insulation materials and sealed if there is no sealing cover plate.
- (5) When lithium batteries are to be stored, the charge should be above 30%. In order to prevent over discharge during long-term storage (more than 3 months), batteries should be charged regularly, keeping the charge at 50%-80%.
- (6) It is required to conduct a charge check once a month for those long-term parking vehicles. After check, make sure the charge is between 50% and 80%. Charge it till the required amount if the charge is insufficient.
- (7) Long-term idle lithium batteries need periodic charge-discharge activation and a standard charge-discharge cycle once a month.

## 7. Inspection before operation:

For the sake of safety operation and good situation of the electric truck, it is compulsory to check the truck completely before operation. Contact the sales department of our company when founding problems

### 7.1 Check point and check content:

	No.	Check point	Check content
Braking system	1	Operation handle	When the operation handle is turned, with the handle switching between area A and B, there is a noise from the brake.
	2	Brake clearance	The clearance between brakes should be kept between 0.2mm and 0.8mm.
Steering system	3	Operation handle	Degree of tightness and rotary flexibility.
	4	Oil pipe	Leakage or not.
	5	Hydraulic oil	Appropriate oil quantity.
	6	Lifting oil cylinder	Whether there is any oil leakage.
Wheels	7	Pins, screws and all the fasteners	Check all the fasteners of the truck's wheels, i.e. pins or screws, loose or not.
	8	Wearing status	Compare the parameter lists, replace the wheel when its diameter reduces by 5%.
Storage battery	9	Charge	Confirm the display state of the battery capacity.
	10	Electrolyte	The solution level and density of electrolyte.
	11	Connecting line	The connecting line and socket shall be firm.
Horn	12	Horn	Press down the horn button to check whether the horn sounds.
Instrument	13	Function	Turn on the switch of electric lock to check whether the instrument displays normally or not.
Others	14	Truck frame, etc	Damaged or not. If there is any crack.
	15	Function	Check that whether lifting, lowering, forward & backward movement and emergency reverse of the truck is normal, and if there is any abnormal noise.

## 8. Inspection after operation:

After operation, the smudge on truck shall be wiped out. Besides, the following check shall be truckried out:

Keep visibility of all graphics context marks such as warning signs, nameplates and notice board. These marks are able to instruct, caution and warn the operator to some degree.

The situation about deformation, distortion, damage or breakage.

Add lubricating oil and grease if necessary.

Replace faulty components.

## 9. Periodic maintenance and repair:

Comprehensive check for truck can avoid malfunction and ensure the service life. The hours listed in maintenance procedures is based on the cases that the truck works for 8 hours per day and 200 hours per month. For the sake of safety, maintenance shall be truckried out according to maintenance procedure.



### Notice

All the repair work shall be truckried out by professional personnel

Please contact the sales department of our company if you need to adjust or replace the components.

### 9.1 Precautions during maintenance:



### Notice

The components for replacement shall be produced completely by our company. When replacing components of the truck, the components with the same safety requirement with the original design shall be used. The lubricating oil and hydraulic oil in use shall be recommended by our company.

(1) Places for maintenance:



### Notice

The places for maintenance shall be appointed and can provide other services such as hoisting and safety protection facility etc.

The places shall have level ground and good ventilation.

The places shall be equipped with fire-extinguishing devices.

(2) Precautions before repair and maintenance:



### Notice

No smoking.

Arrange the self-protection work.

Wipeout the effusive oil in time.

Before adding lubricating oil, clean up the dirty oil or dust on the joint with brush or cloth.

Except certain situation, turn off the key switch and pull off the power socket.

Lower down the fork arms to the lowest point when truckrying out maintenance.

Ensure no goods on the truck when demounting the high pressure oil pipe. Besides, the fork arms shall be descended to the lowest position, by this way, the pressure of hydraulic system can be released.

For the reason that there are capacitors storing a little amount of electric energy in circuit, so before contacting the binding post of the main circuit, discharge at first.

Clean the electric section with compressed air, never flush with water.

When the truck requires high-position maintenance, the altitude safety protection must be truckried out for the repairing and maintenance personnel.

### 9.2 Inspection and maintenance before the new truck put into operation

In order to follow the industry related regulations and ensure the absolute security to the truck in the transportation, for new ex-factory truck, it is possible that there is no electrolyte inside storage battery before the first use (except the inland sale).

The electrolyte of storage battery is prepared well before the truck leave the factory, and it is filled into the storage battery by the professional personnel before the first use. First, place the truck to the site with good ventilation, open the lid of storage battery box, and open all the top plastic lids of storage battery. The plastic

pot with storage battery electrolyte inside is raised using plastic funnel, and the electrolyte is poured into the storage battery in a slow way until the liquid level can be seen. After all the storage battery is filled, conduct initial charge to the storage battery timely according to the operation requirements of initial charge 5.1.

### 9.3 Daily inspection

Inspection of hydraulic oil level: lower the fork to the lowest position, and oil charge is 12L. Recommendatory trademark for the hydraulic oil should be chosen.

Check the capacity of storage battery: refer to the use and maintenance of storage battery.

### 9.4 The inspection according to the need

Clean the truck

Inspect and screw down each fastener

Inspect the damage state of wheels

### 9.5 The inspection and maintenance after 50 hours (Weekly)

Braking system	1	When the operation handle is turned, with the steering handle switching between area A and B, there is a noise from the brake.
	2	The oil dirt and dust on the turning gearwheel should be cleaned.
	3	The clearance between brakes should be kept between 0.2mm and 0.8mm
Capability of electrolyte	4	Inspect the liquid level of electrolyte, pure water can be used for supplement if the liquid level is too low.
Density of electrolyte	5	The specific gravity should be 1.28g/ml after charged.
Clean the storage battery	6	Cover the lid, and flush with tap water.
Inspect the contactor	7	Burnish the coarse surface of contacts using sand paper.

### 9.6 The inspection and maintenance after 200 hours (Monthly)

Besides the weekly maintenance, the following maintenance should be truckried out, and when the parts must be adjusted and replaced, please contact with maintenance personnel of our company. (keep monthly maintenance record)

	No.	Check point	Check content
Whole truck	1	Whole status	Abnormal or not.
	2	Horn	Sound
Steering system, braking system, hydraulic system and lifting system	3	Operation handle	When the operation handle is turned, with the handle switching between area A and B, there is a noise from the brake.
	4	Brake clearance	The clearance between brakes should be kept between 0.2mm and 0.8mm.
	5	Operation handle	Degree of tightness and rotary flexibility.
	6	Truck frame and fastener	Function, and check cracks, lubrication and tightness of fasteners.
	7	Connecting rod and wheel truckrier	Function and check the cracks, bending, deformation and lubrication condition.
	8	Oil pipe	Whether oil pipes leak or not.

	9	Hydraulic oil	Proper quantity of oil.
	10	Lifting oil cylinder	Whether there is any oil leakage or not.
Storage battery, charger and electric system	11	Electrolyte	Liquid level, specific gravity and cleanness
	12	Plug	Function, whether it is damaged or not
	13	Key switch	Function
	14	Contactor	Contact performance and function
	15	Inching switch	Function
	16	Controller	Function
	17	Driving motor	Wearing status of truckbon brush and selenium rectifier.
	18	Lifting motor	Wearing status of truckbon brush and selenium rectifier.
	19	Steering motor	Wearing status of truckbon brush and selenium rectifier.
	20	Fuse	Whether it is perfect or not
	21	Wiring harness and connection terminals	Whether flexible and whether damaged or not.

### Adjustment of the brake clearance

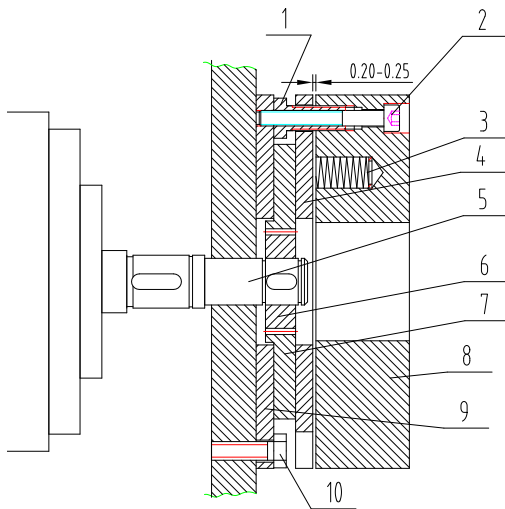

- |                        |                        |
|------------------------|------------------------|
| 1 Hollow screw         | 2 Fitting screw        |
| 3 Spring               | 4 Armature             |
| 5 Motor shaft          | 6 Spline housing       |
| 7 Friction plate       | 8 Electromagnetic coil |
| 9 Mounting cover plate | 10 Mounting screw      |

1. The structure of brake is shown as the figure. After a period of use, performance of the brake will decline due to the wearing and tearing of the brake plate. Then it is necessary to adjust the clearance of the brake. As indicated in the drawing, first use the insert ruler to check the clearance between the brake plate and magnetic steel. If the clearance is over 0.5mm, adjust it. Before the adjustment, clean the dirt and dust on the friction plate.

During adjustment, first loosen the fitting screw.

2. Then adjust the length of the adjustment screws 1 and screw down the tightening screws. After the adjustment, the clearance between brake plate and magnetic steel shall be kept between 0.2-0.3mm. During the adjustment, make sure that the three tightening screws are adjusted evenly so as to ensure that the clearance between brake plate and magnetic steel are distributed around equally. After the adjustment, turn on the brake with 24v DC power. Then the brake will make clear sound.

### 9.7 Maintenance for 600 hours (every three months)

During the maintenance every three months, the monthly maintenance process shall be repeated. When the parts must be adjusted and replaced, please contact with maintenance personnel of our company.

Contactor	Burnish the coarse surface of contacts using sand paper.
-----------	--

	Replace according to the status when the function is not well.
Motor	Wearing status of truckbon brush and selenium rectifier.
Brake	Clean the dirt and dust on friction plates of the brake, meanwhile check the wearing status of the friction plates.

### 9.8 Maintenance for 1200 hours (every six months)

During the maintenance for a half year, the maintenance process for three months shall be repeated. When the parts must be adjusted and replaced, please contact with maintenance personnel of our company.

Contactor	Burnish the coarse surface of contacts using sand paper.
	Replace according to the status when the function is not well.
Motor	Wearing status of truckbon brush and selenium rectifier.
Decelerate box	Replace the gear oil
Oil filter	clean
Brake	Clean the dirt and dust on friction plates of the brake, meanwhile check the wearing status of the friction plates.
Hydraulic system	Replace hydraulic oil. Check that whether there is any leakage in the lifting cylinder or not and replace the seals when necessary.
Fork wheel and bearings	Check the wearing condition, and replace them if necessary

### 9.9 Recommended working medium:

(1) Hydraulic oil:

A. When it is normally loaded, we advise:

Hydraulic oil: LHPISOVG46, in accordance with standard DIN51524T.2, the average sustained temperature should between 40 degrees to 60 degrees.

B. When it is over loaded, we advise:

Hydraulic oil: LHPISOVG68, in accordance with standard DIN51524T.2, the average sustained temperature is above 60 degrees.

C. When it is lightly loaded with low temperature, we advise:

Hydraulic oil: HLPISOVG32, in accordance with standard DIN51524T.2, the average sustained temperature is below 60 degrees.

D. At the occasion with variable loading, we advise:

All the working conditions mentioned above can use the hydraulic oil LHPISOVG46 in accordance with standard DIN51524T.2 for replacement. The viscosity of this lubricant is very high (mostly used hydraulic oil).

If it is difficult to buy hydraulic oil, SAE20W/20 engine oil can be used to substitute HLP68 hydraulic oil.

(2) Gear oil:

Hyperbola gear oil 85W-90(GL-5)

(3) Lubricating grease:

Lithium grease of type 3

All kinds of depleted hydraulic oil, gear oil and grease will pollute the environment. For this reason, recycle the replaced working medium or treat according to local pertinent regulations

### 9.10 Maintenance period of consumables and partial parts:

Items	Maintenance content	Maintenance period	Remarks
Bearings of fork wheel	Replacement	1200 hours	
Fork wheel	Replacement	1200 hours	
Seals	Replacement	1200 hours	Replace when finding out damage
Gear box	Replacing lubricant grease	1000 hours	
Hydraulic oil	Replacement	1000 hours	
High pressure oil pipe	Replacement	2000 hours	Replace when finding out damage
Strainer of hydraulic reservoir	Cleaning	1000 hours	
Driving motor	Check for truckbon brushes and bearings	1000 hours	
Steering motor	Check for truckbon brushes and bearings	1000 hours	
Oil pump motor	Check for truckbon brushes and bearings	1000 hours	

## 10. The store, transportation and loading of truck:

### 10.1 The store of truck:

If the electric pallet staker is not used for over two months, it should be placed in the room which is in good ventilation, no frost, clean and dry; also the following measures should be taken:

Clean the truck thoroughly.

Lift the forks completely for several times, check it is normal or not.

Lower the forks to the lowest position.

Support the side near to driver of truck with square timber to lift the driving wheels of truck from the ground.

Apply a layer of flimsy oil or grease on all the bared surface of mechanical parts.

Lubricate the truck.

Check the status of storage battery and electrolyte, and imbrue the non-acid lubricating grease to the binding post of storage battery.

All the electrical contacts should be sprayed using appropriate contacts spray.

### 10.2 Transportation of truck:

If the truck needs to be transported for a long distance, support the side near to driver of truck with square timber to lift the driving wheels of truck from the ground. The two front wheels of truck shall be fixed stably by sphenoid wood block. Fasten the truck to transport truck with ropes.

### 10.3 Loading and unloading of truck:

Before loading the truck, check out the nameplate for the total weight of truck to choose appropriate hoisting handling equipment. The hoisting of truck shall be kept level, and landing shall be kept slow and stable. The personnel around shall watch for safety. One of the personnel is responsible for conducting. If the other truck is used for loading and unloading, please watch the bottom situation of the truck. Take trucke to insert the fork arms to the bottom, in avoidance of damaging the driving wheel, balance wheel and forward wheel.

## 11. Replacement of storage battery

The replacement procedure of storage battery is as follows:

1. Open the side door of storage battery and take it down.
2. Pull down the socket connector of storage battery from the truck.
3. Pull out the pin of battery case to loosen the battery.
4. Pull out the storage battery from the side way and take the storage battery away with special truck or using hoisting method.
5. The mounting method of putting the storage battery back into the battery pack is opposite to the above procedures.



### Notice

Handle the storage battery gently during hoisting and transportation of the battery. Otherwise it will cause damage to the battery or bring danger to human body.

## 12. Common faults and trouble shooting:

No.	Faults	Possible causes	Trouble shooting
1	The stacker can not start.(The contactor does not work either)	① The fuse of control circuit is burnt out.	Replace
		②The power switch is in poor connection or is damaged.	Repair or replace
		③ Fuse of main circuit is blown.	Replace
		④The switch of electric lock is in poor connection or damaged.	Repair or replace
		⑤The connection of the storage batteries is loose or has fallen off.	Tighten
	The stacker can not start.(The contactor works.)	① The side-magnetic brake of the drive wheel does not suck and the stacker is in a braked condition.	Repair or replace
		②The walking motor truckbon brush is worn or bad contact between the steering device and the truckbon-brush.	Repair or replace
		③ The magnet-exciting coil of the stepper motor is broken or bad contact at the wire end.	Repair or replace
		④ Bad contact.	Repair or replace
		⑤ There is a trouble at the MOSFET tube type circuit board.	Repair or replace
2	The stacker can only move forward or backward.	①The contactor is in poor connection or burnt out.	Repair or replace
		② There is malfunction in circuit board.	Repair or replace
3	The stacker can not stop during traveling.	Broken contact. The moving contact cannot be reset.	Cut off the power at once and replace the contact
4	The brake does not work	①The erection bolt of the fine motion	Adjust or tighten the

		switch looses or is damaged.	bolt or replace the fine motion switch.
		②The connecting wire of the side-magnet brake is loose or damaged	Tighten the bolt or repair the side-magnet brake.
		③ The braking plates of the side-magnet brake are worn.	Replace the braking plates.
5	The steering has got stuck	① The bearing of the steering device is damaged.	Replace the bearing
		② The bearing of the steering device lacks lubricant or there is too much dust	Clean the bearing
6	Difficult steering of the drive wheel, noise and the motor is overloaded.	①The gear or bearing has got stuck because of foreign matters.	Clean or replace the bearing
		②There is a gap in the bearing installed	Adjust the clearance
		③The front wheel bearing is damaged.	Replace the bearing
7	The forks cannot be lifted.	①Overload	Reduce the load
		②The pressure of the overflow valve is too low	Adjust the pressure higher
		③Internal abnormal leakage in the lifting oil cylinder	Replace the seals
		④Insufficient hydraulic oil	Add appropriate quantity of filtered hydraulic oil
		⑤ Insufficient voltage of the storage battery	Charge the battery
		⑥ The control handle is not horizontal or vertical, the oil pump motor has not been turned on.	Improper operation
		⑦ Damaged oil pump motor	Repair or replace
		⑧ Damaged oil pump	Repair or replace
		⑨ Damaged lifting button	Repair or replace
		⑩ The electric lock is not unlocked or is damaged.	Repair or replace
		⑪ Seriously insufficient voltage in the cell.	Recharge
8	The forks cannot be lowered after lifted.	① The internal mast is overloaded and deformed	Repair or replace
		② The external mast is overloaded and deformed	Repair or replace
		③ Dead mast roller	Repair or adjust
		④ Mast guiding rode is curved	Repair or straighten
		⑤ The oil return hole is blocked	Clean
		⑥ The electromagnetic valve is out of control	Shoot the trouble
9	Reduced end voltage of	① Damage of individual battery	Repair or replace

	the storage battery (after charged)	② Low level of the electrolytic solution	Add electrolytic solution
		③ Foreign matters in the electrolytic solution	Replace electrolytic solution
10	The truck shakes while traveling.	① Driving wheel locating nuts loosen or come off.	Screw down the locating nuts.
		② The balance wheel, driving wheel and the two front wheels are not in the same plane.	Adjust bolts on the balance wheel to make the four wheels in the same plane.

### 12.1 Adjustment methods of safety valve pressure

The pressure of safety valves has already been adjusted when the truck is ex-factory. Users shall not adjust the pressure at will. Otherwise it will bring danger to the truck's hydraulic system and safety. If the oil pressure is not in accordance with specified value, please ask the professional personnel to adjust according to the test methods stipulated in the JB/T3300 standards as well as the following methods:

- 1) Screw out high pressure oil tube and install pressure meter with capacity over 20Mpa at the high pressure oil outlet.
- 2) Press lifting operation button to measure the system pressure. The stipulated system pressure is 11.5Mpa for truck with rated load of 550KG and 12 Mpa for truck with rated load of 600KG.
- 3) If oil pressure is not in accordance with the specified value, please loosen locknuts of the overflow valves. Turn pressure screw left and right until the pressure reaches the specified value. When the screw is turned clockwise, the system pressure increases. While the screw is turned counter-clockwise, the system pressure decreases.
- 4) After the adjustment, please screw down the locknuts.

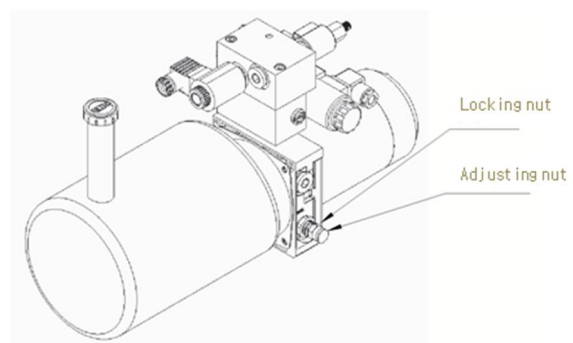

## 13. Common fault signal and troubleshooting

No	Programmer Display	Code	Fault	Fault diagnosis
1	BATTERY DISCONNECT FAULT	4.5	Battery disconnected	1) Battery disconnected 2) Loose contact of the battery end
2	BRAKE OFF FAULT	3.4	Brake shutdown fault	1) Electromagnetic brake coil short circuit 2) Electromagnetic brake driver is open
3	BRAKE ON FAULT	3.2	Brake opening fault	1) Electromagnetic brake coil has a short circuit 2) Electromagnetic brake driver is open

4	CURRENTSENSE FAULT	4.1	Current sense fault	1)Motor or motor wiring has a short circuit 2)Controller fault
5	EEPROM CHECKSUM FAULT	4.3	EEPROM fault	1) EEPROM fault or failed
6	HARDWARE FAILSAFE	4.2	Motor voltage is beyond the range	1)Battery voltage does not match accelerator input 2)Motor or motor wiring has a short circuit 3)Controller fault
7	HPD FAULT	3.5	HPD fault	1)Disordered operations among the accelerator, key switch, implement and disabled input. 2)Adjust the accelerator wrongly
8	MAIN FAULT	2.3	Main contactor fault	1) Main contactor adhered or open 2)Main contactor coil driver fault
9	MAIN OFF FAULT	2.1	Coil drive of the main connector shut down failure	1) Wrong opening of the main contactor coil
10	MAIN ON FAULT	2.4	Coil drive of the main connector opening up failure	1) Wrong shutdown of the main contactor coil
11	OVERVOLTAGE FAULT	1.5	Battery voltage is too high	1) Battery voltage > 31V 2)Charger is connected while traveling 3) Battery loose connection
12	PRECHARGE FAULT	3.3	Precharge fault	1)Controller fault 2)Low battery voltage
13	SPEED POT FAULT	1.3	Fault of speed limiting potentiometer	1)speed limiting potentiometer has a short circuit or open 2)speed limiting potentiometer is open
14	THERMAL FAULT	1.1	Over/lower temperature cut-off	1)Temperature>80°C or < -10°C 2) the truck is overloaded 3)Running under an extreme environment 4)Abnormal electromagnetic brake release
15	THROTTLE FAULT	1.2	Potentiometer sliding end or low end voltage is out of range	1) Accelerator input is open or has a short circuit 2)Accelerator potentiometer failure 3)Wrong accelerator model
16	UNDERVOTAGE FAULT	1.4	Battery voltage is too low	1) battery voltage <17V 2) loose connection of the battery or the connector
17	WIRING FAULT	3.1	HPD failure time is over 10 seconds	1)improper operation on the accelerator 2)accelerator end or its mechanical part failure

## 14. Lists of accessories, spare parts and vulnerable parts

### 14.1 Lists of CPD05W (without full free lift) accessories, spare parts and vulnerable parts

No.	Name	Use position	Specification	Qty	Remarks
1	Key	E-lock		2	
2	Fuse	Electric part	50A	1	
3	Fuse	Electric part	125A	1	
4	Seal ring	Cylinder	UHS35	1	
5	O-seal ring	Cylinder	40X2.65	1	
6	Combined ring	Cylinder oil inlet	D14	1	
7	Dust ring	Cylinder	DHS35	1	

### 14.2 Lists of CPD10W (without full free lift) accessories, spare parts and vulnerable parts

No.	Name	Use position	Specification	Qty	Remarks
1	Key	E-lock		2	
2	Fuse	Electric part	125A	2	
3	Seal ring	Cylinder	UHS35	2	
4	O-seal ring	Cylinder	40X2.65	1	
5	Combined ring	Cylinder oil inlet	D14	1	
6	Dust ring	Cylinder	DHS35	1	

## 15. Structure diagram (explosion diagram) and principle diagram

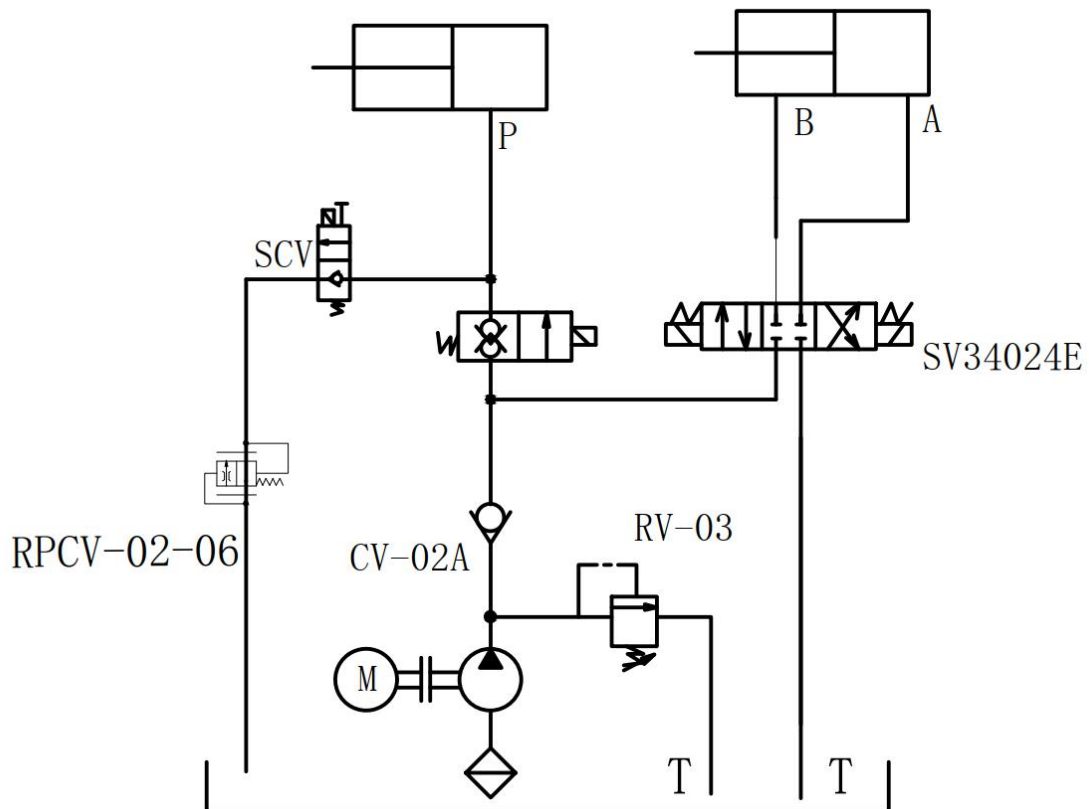

Hydraulic schematic diagram

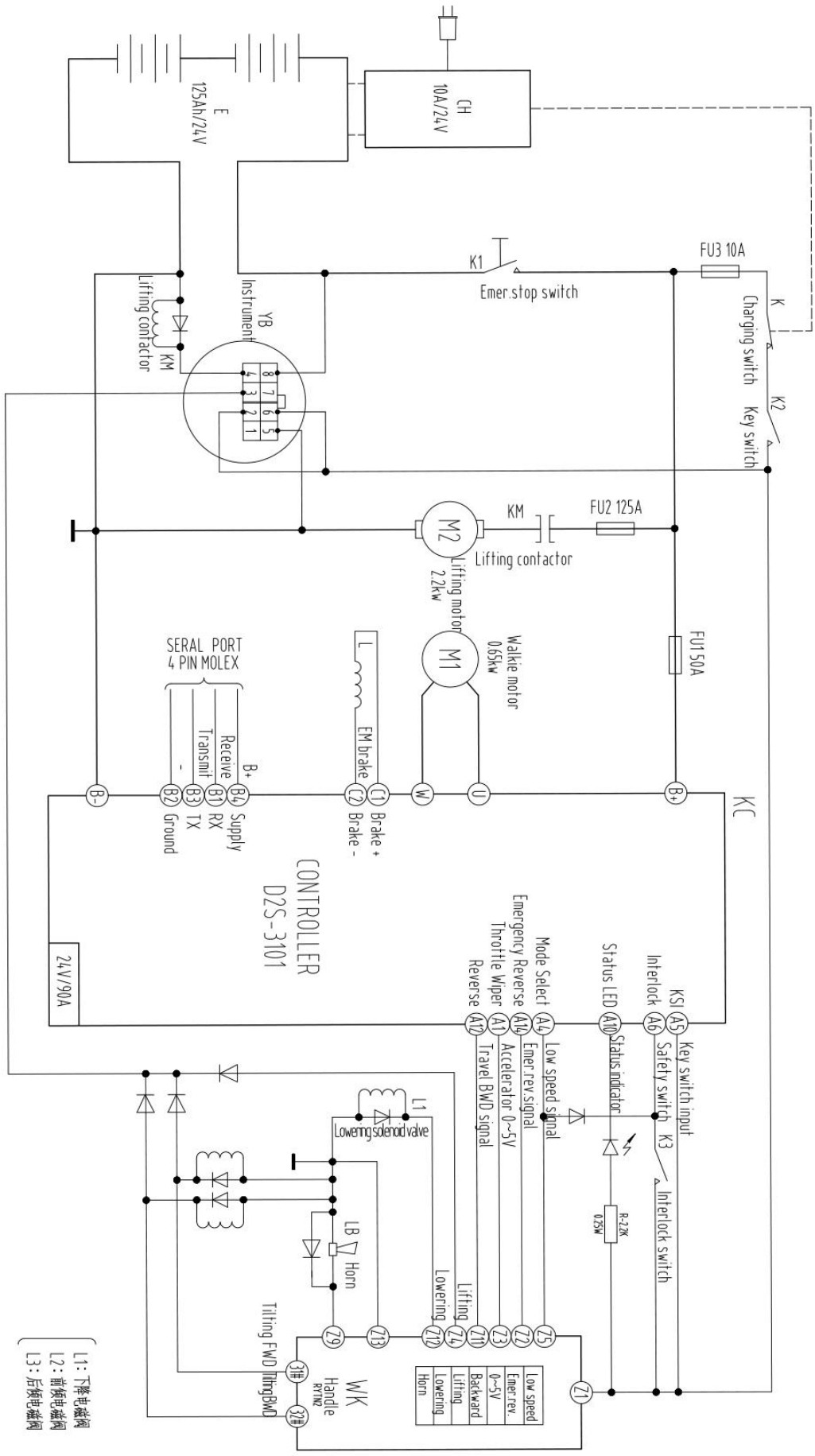

**CPD05W Electrical schematic**

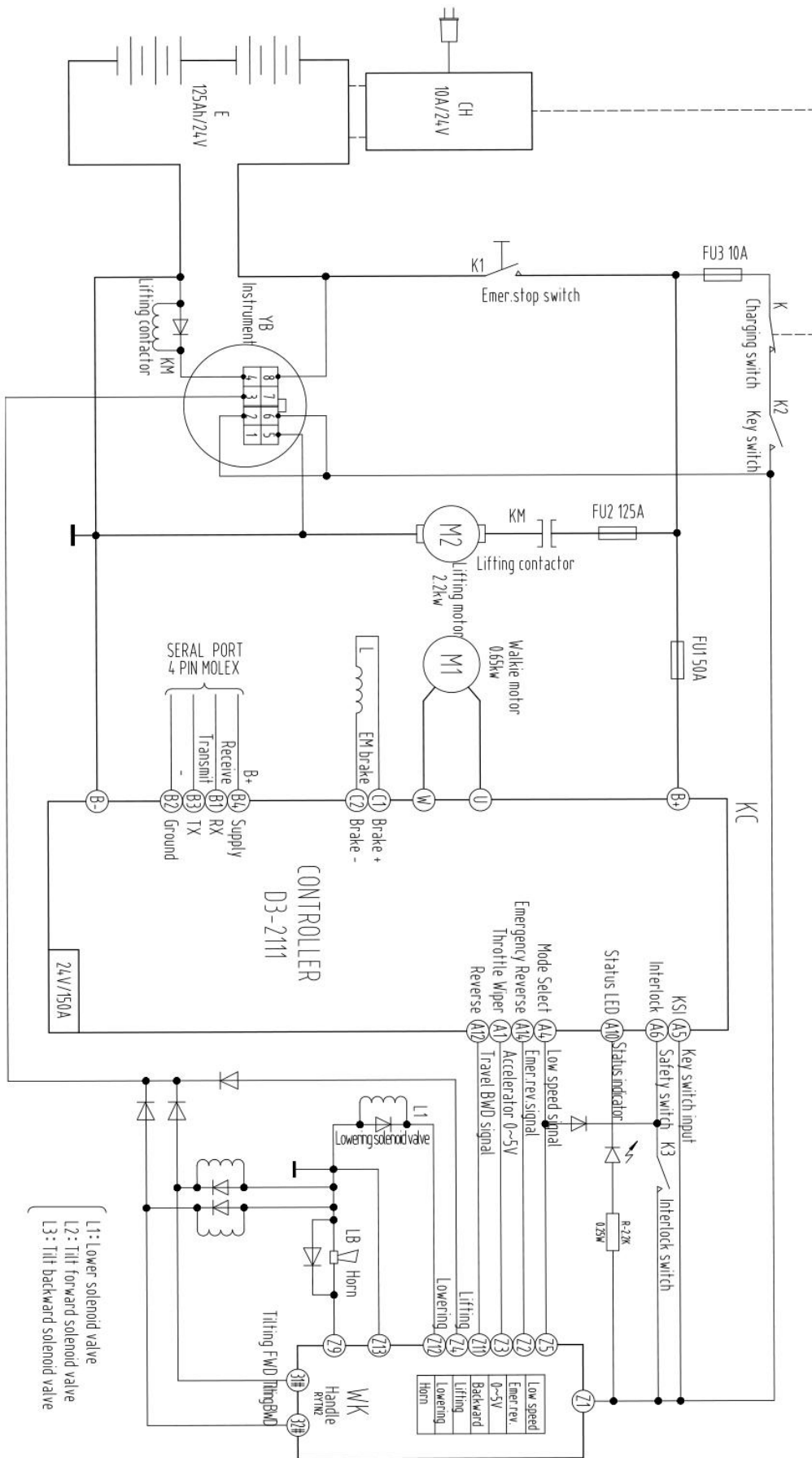

**CPD10W Electrical schematic**

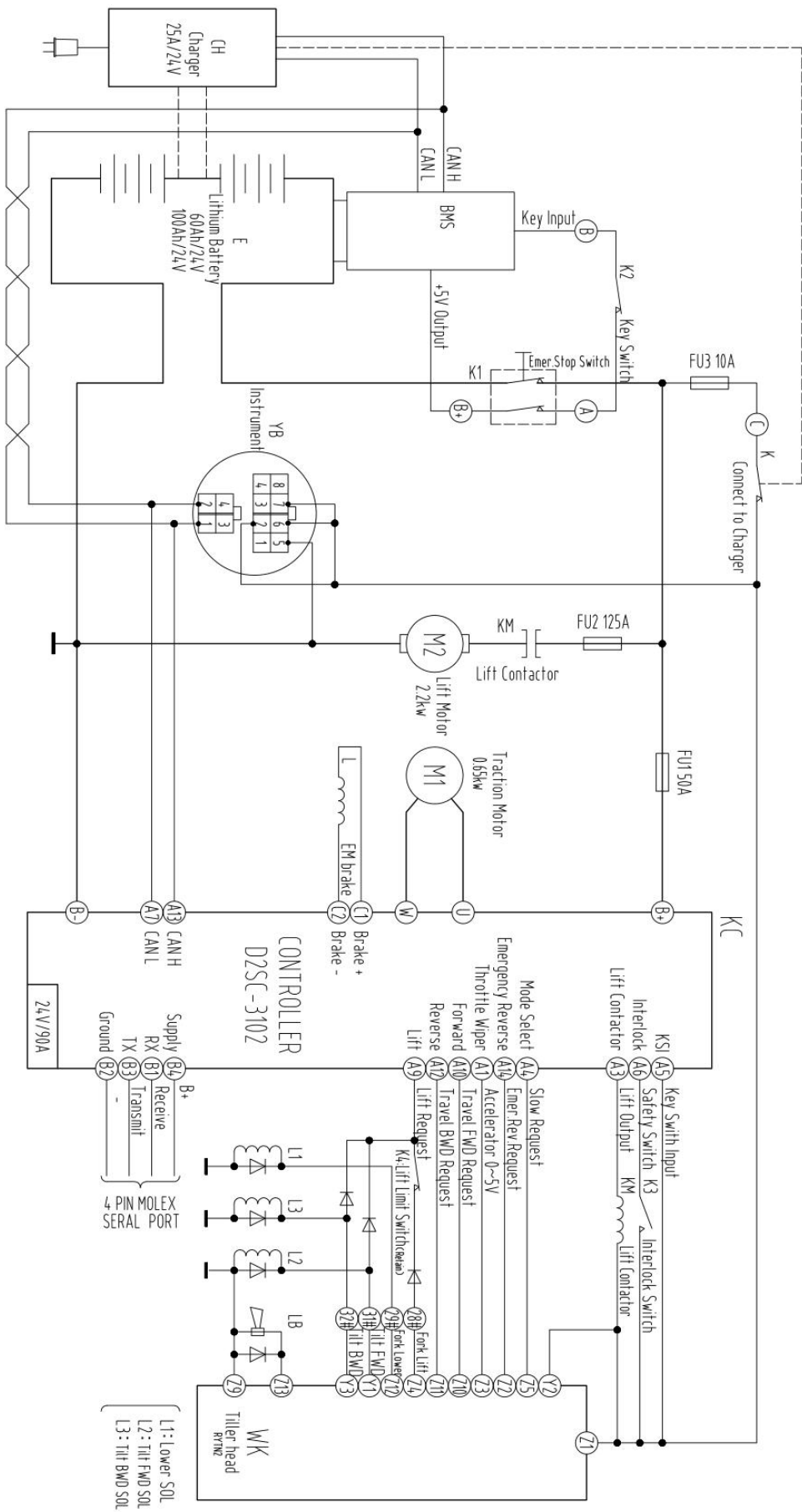

**CPD05W-Li Electrical schematic**

## 16. Packing list

Packing List of CPD05W/ CPD10W (without full free lift) electric counterbalance stacker

Consignee:

Ex-work No.:

Contract No.:

Ex-work Date:

No.	Name	Quantity	Net weight (kg)	Dimension (L×W×H)	Remarks
1	CPD05W/CPD10W electric counterbalance stacker	1			A complete set.
2	Accessory box	1			Technical documents, accessories and spare parts.

Note: 1. The following documents are in the file bag:

- |  |          |
|--|----------|
| ① Operation manual of CPD05W/ CPD10W electric counterbalance stacker | 1 volume |
| ② Packing list   | 1 copy   |
| ③ Qualification certificate  | 1 copy   |

### 2. Accessories and spare parts

No.	Name	Use position	Specification	Qty	Remark
1	Key	Electric lock		2	
2	Fuse	Electric equipment	10A	1	
3	Fuse	Electric equipment	100A	1	
4	Sealing ring	Cylinder	UHS38	1	
7	O-seal ring	Cylinder	45X2.65	1	
8	Composite ring	Cylinder oil inlet	D16	1	
9	Dustproof ring	Cylinder	DH38	1	

Consigner:

## Powered industrial trucks—Safety code

### **The Second Part Safety Code of motor industrial trucks in service, operation and maintenance**

- 14 Safety rules for the user and driver  
In order to use the motor industrial truck well, this part set up some rules. The 14.1 is applied to the user, the 14.2 is for the driver.
- 14.1 Applied to the user  
The users are the owner or the leaser individual or corporation of the truck.
- 14.1.1 The qualification of the driver  
The driver of the motor industrial truck should be trained, pass examination and get the operation qualification.
- 14.1.2 The truck working in flammable and explosive circumstance  
Only the industrial motor truck getting the qualification of the national authoritative department and getting the license of working in the flammable and explosive circumstance, should work in the circumstance.  
This kind of truck should be marked with proper stamp sign, and the relevant building or the plant should be marked too.  
The classification of the building or the field condition should agreed on by the user and the national relevant authoritative department.
- 14.1.3 Passenger  
Except for special seats, the truck can not truckry passengers. The passengers are forbidden to step on the ascent machine or the attachment, except for the following conditions:  
The truck mounted working platform (except for the high-lift order picker):
- A) The platform should be fixed on fork rack/ fork firmly.
  - B) If there is no ascent control device, when there is person on the platform, the driver should leave the driving position.
  - C) When there is person standing on the platform with ascent control device, only this ascent control device on the platform can be used.
  - D) The overall weight of the platform, the load and the people should not over the half of the weight marked on the truck nameplate.
  - E) The platform on the truck should not be used to transport people. But if for the hand work, the truck can be adjusted for operation in a small range.
- 14.1.4 The use of the forklift
- 14.1.4.1 The change of the capacity and nameplate of the truck  
The truck in use shall not exceed the rated capacity stipulated by the factory.  
Without the permit of the factory, any amendment of the design is forbidden, and should not add any attachment on the truck, in order to prevent the influence of the capacity and operation safety of the truck.  
Any changing because of adding attachment should not reduce the security and accord to the requirement of this rule. After adopting the attachment, the capacity of the truck, the operation and the repair direction board, label or pattern should be altered correspondently.  
The user should ensure all the nameplate and label in proper position, and maintain handwriting clear.

#### 14.1.4.2 Stability

The user should pay attention to section 6 of the code, which is about the stability of the truck in the working conditions.

When operating correctly, the high lift truck accord with the section 6 is steady, but the incorrect operating or the wrong maintenance could let the truck working unsteadily.

The factors that may influence the stability are: the condition of the ground and the floor, gradient, speed, load, the weight of the storage battery, the dynamic force and the static force as well as the judgment train conditions of the drivers.

When the truck is working in the condition differ to the regular working condition stated in the section 6, should reduce the load.

When the truck mounted attachment working without load, it should be viewed as partial load.

#### 14.1.4.3 The protection requirement and protection equipment

The truck should be painted with obvious color differing from the surrounding circumstance.

The driving type high –lift truck should be mounted with protection cabane, except for the condition where the load could not drop onto the driver.

When convey the load maybe fall to the driver using high –lift truck, should adopt shielding shelf with enough height, weight and the opening size is small enough to prevent the entire load or part of them from falling onto the driver.

When it is necessary to denote the working condition, the truck should add caution device, such as light or flash lamp.

In the permit of the factory, it is allowed to install turning hand hold on the steering wheel formerly without it.

#### 14.1.4.4 The transportation and storage of the fuel

The truck should refuel in the stated place. The fuel station should be ventilated, in order to reduce the accumulation of the fuel gas to the least. In opening pit, subway entrance, and lift well or other similar conditions nearby should not fill in the liquefied petroleum gas and replace other dismountable liquefied petroleum gas container.

It is forbidden to smoke in the place of refuel, and should alarm using platruckd.

If the liquid fuel is not transport using pipeline, it should be transported using airtight container.

Only the personnel trained and appointed can fill or change the liquefied petroleum gas container.

When store and transport the liquefied petroleum gas container, should fasten up the filling valve, and the safety valve should connected to the vaporization room directly. When storing the container, should screw the protective cap on the connection mouth.

Before filling and/or reusing, should inspect the container to ensure that it is vapor proof. Especially pay attention to the valve and the connective part is vapor proof. The damaged container should not be used. Only the permitted corporation could repair the liquefied petroleum gas container.

#### 14.1.4.5 The charging and changing of the battery

The battery charging station should set in the appointed area. The charging station should prepare the equipment using for flushing and neutralizing the overflow electrolyte, the fire control device, the measure avoiding the truck damage the charging device and the adequacy ventilation facility blow away the fume off from the battery.

In the area of charging, it is forbidden to smoke and alarm with platruckd.

Only the personnel trained and permitted can change or charge the battery. The battery repairing people should wear protective clothes.

All the work of changing the battery should truckried out according to the description of user's manual from the factory. When reinstall the battery, should adopt measures to make the battery

connecting, orientation and fixation correctly. Do not put tools and other metal substance on the lidless battery.

Without the special approval (for example the truck factory), the electrical motor truck should not change the battery with different voltage, weight or size.

It is obliged to use the battery stated by the factory. It is obliged to prepare the facility for changing battery safely. When hanging up the battery using hoisting equipment, it is necessary to use insulated steeve.

If adopting chain hoist, it is necessary to equip chain box. If adopting chain block, the lidless battery should be covered by a piece of rubber blanket or other insulated materials, to prevent the short circuit of chain and the connecting wire or connecting terminal between the battery lattice.

#### 14.1.4.6 The invalid or damaged truck

If finding the motor industrial truck existing insecurity factors, it should stop using and give away on the spot. After repairing and recovery to the safety conditions, it can be reused.

#### 14.1.4.7 Accident

Once the accident happens, for example the staff injures, the truck damages the building or the equipment, firstly should organize salvage, do best to protect the accident field and report to the governor.

#### 14.1.5 Operating conditions

##### 14.1.5.1 Channel and stacking field

The ground of the operating field should have enough truckrying capacity, and it is necessary to maintain it well not to influence the truck operating safely.

The transporting channel of the truck should have well visual field, and it is easy to turn, and no grade, steep slope, narrow channel and low roof board. The outline or the borderline must be clear. In the road where it is easy to meet the stepping truck, the width of the channel should be adjusted. Advising the grade of the channel should not over 10%, the top and the bottom of the slope should transit smoothly, to prevent the load vibration or the bottom of the truck from colliding the ground. When the grade is over 10%, installing a sign is advised.

If the truck is in operation (transport) and the load block off the sight, when the truck is operating, the load should located on the backward of the truck operation direction.

For example: in some conditions (for example stacking and climbing), when the truck is operating, the load is required on the forward of the truck operation direction. Then, the driver should drive the truck truckefully. It is necessary to attend: if the operation condition require, should equip accessory (assistant) equipment or assistant.

The passage, road, runway, floor or slope should maintain good operating conditions, to prevent the truck or the load from being damaged, and to prevent reducing the stability of the truck.

In dangerous state, including the barrier danger on the top, should mark on the clear location.

The fire fighting passage, the upstairs passage and the fire fighting equipment should maintain expedite.

##### 14.1.5.2 Gangplank or transition board

All the gangplank or transition board should has enough safety coefficients to bear the truck with load. On the gangplank or transition board should marked the max passing load perpetually.

The gangplank or transition board should fixed firmly, to prevent the accidental move, vibration or slide.

On the gangplank or transition board should equipped handing or other available equipment to the effect of safety transport. On the conditions of possible, should set the fork hole or suspending ear for moving goods.

The gangplank or transition board should have non-slip finishing.

On the both sides of the gangplank or transition board, should mounted the facility to prevent the truck from going over it's edge.

When the gangplank or transition board is fixed its location, should adopt measures to prevent the reverse joint truck from moving suddenly.

#### 14.1.5.3 Lighting

When the photometric brightness on the operating field is less than 32LX, the truck should equipped auxiliary light.

#### 14.1.5.4 The suspending of the truck

The sling should be tied to the lifting spot which the factory appointed.

#### 14.1.5.5 The synchronizing operation of the truck

Conveying bulky or heavy load using two trucks simultaneously is a dangerous operating which requires special truck. And this kind of conditions should be taken as special conditions and truckried out under the supervision of the operator responsible for operation.

#### 14.1.5.6 Elevator (lifter)

The elevator (lifter) for transporting the industrial truck can bear the overall weight of truck, load and the drivers. This kind of elevator (lifter) must be appointed, and the drivers should use the appointed elevator (lifter).

#### 14.1.5.7 Operating on the road truck (trailer) and rail truck

Before the motor industrial truck drive to the road, the road truck should apply the brake and wedging to prevent moving.

Exception: the road truck equipped with automatic snap lock type parking brake can not use the wedge.

The industrial motor truck passing in and out without connect to the tractor, to prevent the semi-trailer hold up can use support.

It is necessary to build up the operating communication and operating order, to prevent the rail truck move accidentally when downloading.

The road truck (trailer) and rail truck should endure the overall weight of truck, load and the drivers.

It is necessary to inspect if the pavement is crushing, having holes or other damage.

When the industrial truck is operating at high place or platform, should not use the industrial truck to move other trucks. Never open the door of the rail truck using industrial truck; expect for equipped with special device and the driver has passed the train to use the device.

### 14.2 Applied to the driver

The safety operating of the industrial truck lies on the control manner of the driver ro a considerable degree. The safety rules applied to the drives are as follows:

- A) general rule;
- B) transporting (lifting and stacking) rule;
- C) operating (driving) rule;
- D) the rule for the driver maintaining the truck.

Without regard to the rules maybe conduce:

- A) the serious danger of damaging the driver or other personnel;
- B) Damage the materials.

#### 14.2.1 General rule

Only the personnel who have been trained and get the qualification of operation are permitted to drive the industrial truck.

The motor industrial truck could not truckry passengers, except for equipped with the facility for the

passengers sitting.

The driver should pay special attention to the operating circumstance, including the person nearby other staves and fixed or moving substances, and it is necessary to watch out for the passerby at any moment.

No matter whether there is load on the lifting part of the truck, it is forbidden anyone passing or standing under the lifting part of the truck.

If the people, building, organization or equipment accident happens, it is necessary to report to the relevant officer at once.

The driver should not change, add or demolish the truck components without the permission to influence the performance of the truck .It is not allowed to install accessorial frame or handle on the steering wheel ,except the factory has installed it.

The driver should use the truck in the using range. When operating high stacking job, convey high and multi-piece piled goods using driving type high-lift truck, it is necessary to use the truck with blind goods shelf and canopy guard shelf.

Exception: if there is no danger of the load fall down on the driver, the truck without blind goods shelf can be used.

When operating high stacking job, convey high and multi-piece piled goods using walking type truck, the blind goods shelf is necessary.

#### 14.2.2 Load truckriage (lifting and stacking) rule

##### 14.2.2.1 Load

The industrial truck or the combination of the industrial truck and attachment only can convey the load not over its rated load weight. The capacity of the industrial truck with attachment maybe less than the one marked on the nameplate.

Any measure of enhancing the capacity of the truck is forbidden, for example the adding people or balance weight.

In any conditions, especially when using the attachment, it is necessary to pay attention to the operation, location, fixation and transportation of the load. The truck with attachment when unloaded should be treated as with some capacity.

Only the rank stabilized or safety load can be conveyed, especially when convey the super long or high load, should pay special truckce.

When convey the load which center of gravity is uncertain, operating the truck should special truckefully.

##### 14.2.2.2 The loading and unloading of goods.

When loading the goods with forks:

- A) The space between the forks should fit the width of the conveying load.
- B) The fork should insert into the inner of the load as deep as possible. But pay attention to not make the fork tip touch the substance except the load. Then the fork should lift to the enough height to move the goods.
- C) When conveying high and multi-piece piled goods, it is necessary to tilt the mast back ward a little (if can tilt back) to stabilize the load, and should be truckceful specially.

When unloading the goods, it is necessary to descend truckcefully. If possible, tilt the mast forward a little (or limited)in order to put ready the load and draw out the fork.

##### 14.2.2.3 Stacking

When stacking, the mast should tilt backward to ensure the stability of the load, approach the goods pile slowly.

When the truck approach and face to the goods pile, it is necessary to adjust the mast to the vertical

location, and lift the load a little higher than the height of the pile. Then running backward the truck Or if using reach truck, extense the fork and descend it to unload the goods.

After lifting, start the truck, no matter with or without load, it is necessary to operate the brake truckefully and placidly.

It is necessary to ensure that the stacking is firm.

After stacking, draw off the fork, and lower the fork to the operating height. After confirm there is no block on the road, drive away the truck.

As for truck can tilt backward , it is necessary to use this function to stabilize the load.

#### 14.2.2.4 Unpiling

The truck approaches the pile slowly, and stopped when the fork tip is 0.3 m far away from the pile. The space of the fork should adjusted to the width of the conveying load, and should check the weight of the load, to make sure the load is in the lifting weight range of the truck.

It is necessary to lift the fork vertically and insert it to the bottom of the goods.

After lifting, start the truck, no matter the truck with or without load, it is necessary to operate the brake truckefully and placidly.

The fork should insert into the bottom of the load as possible. But pay attention to not make the fork tip touch the substance except the load. Then lift the fork to the enough height to move the goods. Further lift the fork, make the goods away from the pile exactly. If the mast can tilt backward, the fork should tilt back properly to stabilize the load. If it is reach truck, it is necessary to draw back the fork.

After make sure the road is smooth, descend the load from the pile.

The fork should be descended to the operation height and the mast tilt backward mostly. After make sure the road is smooth, drive the truck away placidly.

### 14.2.3 Running (driving) rule

#### 14.2.3.1 General rule

The driver should drive the truck along the right side of the road, and the driver should see the road clearly and attend other truck, passengers and safety space.

The drivers should abide by all the traffic rules, including the speed limit specified in the factory.

It is necessary to hold a certain space with the front operating truck.

The driver should drive the truck with earnest and responsible attitude at any time. The sudden starting, stopping and turn over at high speed are forbidden. Except for the requirement of the operation conditions, advising the steering wheel should not put on the limiting position when the truck is starting. If starting on the limiting position, it is necessary to operate truckefully.

The load or the device that bears load must be kept at the operating height when the truck is moving. If possible, the load shall be tilted backward when the truck is running. Except for stacking operation, it is not permitted to lift the load. This regulation does not apply to truck specially designed that can move with lifting load.

In operation (or called transport) state, if the load obstruct the driver's sight, then when the truck running, the load should be located in the back of the truck's moving direction.

Exception: Under some condition (such as stacking and climbing), the load should be located in the front of the truck's moving direction when the truck is moving. At this moment, the driver should drive the truck very truckefully. If operating conditions requires, some subsidiary (attached help) facilities or the other person's lead can be adopted.

In crossroads and the occasion that would obstruct the driver's sight, the driver must reduce the speed of the truck, and issue sound signal.

When the truck is operating with load, the driver must control turning equipment and brake system

slowly and stably.

In crossroads and the occasion that would obstruct the driver's sight or some dangerous occasion, the truck must not exceed other truck moving at the same direction.

The driver must avoid the truck rolling over some fluffy object in order to avoid article damages or personnel hurts.

It is forbidden that to put the arms , legs or the head in the columns of mast or between the truck's other moving components.

When the truck is running, the driver must not let his body outside the contour line of the truck.

When turning, if there are some other trucks or pedestrians, the driver must issue warning signal.

The driver must comply with all labels about ground load trucking capacity and requirements of other instructive labels.

The driver must pay special attention to the load trucking capability of slopes and channels leading to electric elevator.

#### 14.2.3.2 Truck speed

The truck speed should coordinate with the status of person's activity, visibility, road or the ground conditions and load conditions of the running area. When the truck is moving on wet and smooth road surface the driver must be very truckefully.

Under any situation, the truck speed must be controlled within the range that the truck can be stopped safely.

#### 14.2.3.3 Running on the slope

When operating on the slope, the following regulations must be obeyed:

- A) Moving up and down a slope slowly.
- B) Except for the side loading and no lifted load truck, it may as well make the bearing load device's surface towards the downgrade direction.
- C) Turning on the slope and bestride the slope are all forbidden.
- D) When the truck is near the slope, high platform or platform edge, the driver must drive truckefully. The distance between the truck and the platform or platform edge must keep at least a truck tyre width.
- E) When the gradient is more than 10% during the truck's running up and down the slope, if possible, when the lifted load truck and flat stacking truck (except the side bearing load fork-lift truck, cross-country fork-lift truck , stride- truck and platform trucking truck) moves, the load surface must be in a upgrade direction.
- F) When the truck works on various slopes, the load and the load bearing device must tilt backward (if possible), and the driver can only elevate the load's height that is enough for running through the road surface and local barrier.

#### 14.2.3.4 Get across a gap

It must be ensured that under hanging devices (such as: lamps, pipeline and fire extinguishing system) there is an enough clearance height.

Before getting across the passage and door, it must be ensured that there is an enough gap among the truck, the driver and the load.

#### 14.2.3.5 Working in road truck and railroad truck

Before a motor-driven industry truck runs on (or run down) the road truck or railroad truck, some necessary measures must be taken to prevent road truck and railroad truck from moving.

Before a semi- trailer that is not linked with a tractor runs on the road truck or railroad truck ,it must be ensured that the supporting part of the stilt of the semi- trailer is located at the supporting position.

Before a motor-driven industry truck runs on the road truck or railroad truck, it must be ensured that the floor board can endure all the weight of the industry truck, load and the driver. Besides, it is required to check the plank to see if there are crashes, holes or other damages.

When the industry truck works on high place or platform, it is forbidden to move other truck by industry truck. It is also prohibited to close railroad truck's door by industry truck except for one case that the industry truck is equipped with a special device and the driver has also been trained how to use this device.

If possible, the truck should cross over the railway virgule.

#### 14.2.3.6 The truck operating on the gangplank or transition board

Before the motor industrial truck pass the gangplank or transition board, it is necessary to make sure the firm of the board.

The overall weight of the truck should not exceed the rated capacity of the gangplank or the transition board.

When passing the gangplank or the transition board, the driver should drive the truck truckefully and slowly.

#### 14.2.3.7 The use of the truck in elevator (lifter)

Before the motor industrial truck driving into the elevator (lifter), it is necessary to make sure the elevator (lifter) can endure the over all weight of the truck, load and drivers.

Before allow the truck driving in or out of the elevator (lifter),all other personnel should leave away from the elevator(lifter).

After the bridge box floor of the elevator (lifter) is even to the ground, the truck should slowly driving in as the positive direction.

It should be the load go into the elevator (lifter) first not the driver, this is specially adopted to the walking type truck.

After the truck driving into the elevator (lifter), it is necessary to put the control device in the central position. switch off the power, and tighten the brake.

#### 14.2.3.8 Parking

After the driver leaving, the truckrying device must lower to the lowest position, put the control device to the central position, switch off the power, and tighten the brake, stay steady the truck to prevent accidental move or make bold by others without approval.

When parking the truck, the fire fighting passage, access stairs and fire fighting passages should keep fluently.

The parking location of the truck should keep a safety distance to the railway.

#### 14.2.4 The truck maintaining rule for the drivers

##### 14.2.4.1 General rule

Before starting the truck, it is necessary to inspect the technical condition of the truck. According to the different type of the truck, should pay more attention to some special location: [for example: fuel oil system, alarm system, power system, brake, steering equipment, lighting, wheel and air tire pressure (namely gas filled type) and lifting system (including lifting chain, wire rope, limit switch and hydraulic cylinder).

If the truck is found to be repaired, or during the operation the defect develops, it is necessary to report it to the superior in concern. It is forbidden to repair or adjust the truck by the truck by the driver without permission.

The truck which fuel oil system is leaking could not be uses without repair.

##### 14.2.4.2 Refuel

Before refuel, it is necessary to close the engine, brake the truck and the driver should leave the

truck.

The open flame and smoking is forbidden during refueling.

#### 14.2.4.2.1 Liquid fuel (for example gasoline and diesel fuel)

The truck using liquid fuel should add fuel in the appointed places.

Before take away the refueling equipment, cover the filler cap and clear up the excessive fuel, the engine could not start up.

#### 14.2.4.2.2 Liquefied petroleum gas fuel (liquefied petroleum gas)

Only the personnel trained and appointed can refuel or change the liquefied petroleum gas container.

The person charging for refuel liquefied petroleum gas should wear protective suit (that is to say long sleeve unit and glove).

The pouring of the fixed type liquefied petroleum gas container and the pouring and change of the liquefied petroleum gas container should be truckried on the appointed place.

When transporting or conveying the liquefied petroleum gas container, it is necessary to be truckeful, the container should not fall down, nor be thrown, rolling or draw. If it is necessary to transport several containers one time, a proper transporting device should be adopted.

The liquefied petroleum gas container should not be filled in excessive.

Before filling the fuel, power off the engine, brake the truck, and the driver leave away the truck.

It is necessary to using soap liquid to check the leak dictation.

The truck driven by liquefied petroleum gas could not park near the heat source, open flame or the similar ignition, and not near to the open air pit, the entrance of the under crossing, the elevator well or other similar place, and could not change the removable container in the upper place.

Before fill fuel into all liquefied petroleum gas container and before the reuse of the removable liquefied petroleum gas container, it is necessary to inspect if there is defect or damage as follows:

- A) the dent, scoring and groove of the pressure container;
- B) the damage of any kinds of valve and fluid level gage;
- C) the scraping in the safety valve;
- D) the damage or the lose of the safety bonnet;
- E) the leak in the connection of valve or screw-threaded joint;
- F) The deterioration, damage or lose of the flexibility seal in the connection of prime or air feed.

If finding the above defect and/or damage, the container should not be used until repaired.

The truck which is driven by liquefied petroleum gas is over night or stay indoor for a long time and the liquefied petroleum gas container stayed on the truck, it is necessary to close all of the feed valves on the container.

#### 14.2.4.3 The charging and changing of the battery

The charging and changing of all the battery should be truckried out by the personnel who has been trained and appointed staves and proceed as the description of the user's manual of the battery or truck factory. As usual the driver can be appointed.

Before charging or changing battery, the truck should be located correctly and brake.

When charging, the exhaust cap should be in the correct position to prevent the electrolyte spilling out, and make sure that the wind hole is in effect. Open the cover of the battery (or separate room) to exhaust the gas and thermal.

In the battery charging area, should adopt measures to prevent open flame, spark or electric arc. Smoking is forbidden.

The tools and other metal substance should put far away from the top of the battery without cover. The top of the battery should keep dry; the connection terminal should keep clean, wipe a little

vaseline and screw down correctly.

Without approval, the battery of different voltage, weight or size could not replace the former one in the truck.

When reinstalling the battery, the battery should be put on the correct place.

Inspecting the liquid surface in the battery using open fire is forbidden.

When getting the solvent in the acid truckboy, the acid truckboy tilting device or siphon pipe could be used. When diluting oil of vitriol confect the electrolyte, only adding the oil of vitriol into water is permitted, not add water into oil of vitriol.

## 15 Maintenance

### 15.1 General description

Good performance of the motor industrial truck depends upon maintenance. Truck may damage personal health and properties in case of maintenance neglect.

### 15.2 Maintenance items

The following items shall be truckried on for all motor industrial trucks shall be in accordance with schedule, especially with maintenance instructions supplied by the manufacture.

Only professional and qualified maintenance personnel are allowed to go along with the inspection, maintenance, modification and repair.

15.2.1 Brake set, steering mechanism, control mechanism, alarming device, lighting, adjustor, and overload protection device for lifting shall be kept within safe operation condition.

15.2.2 Regular inspection shall be taken for components and members of lifting and inclination systems, which shall be kept within safe operation condition.

15.2.3 Regular inspection shall be taken for safety protection shelf and safety devices, which shall be kept within safe operation condition.

15.2.4 Regular inspection and maintenance shall be taken for all the hydraulic systems.

Inspection must be taken for oil cylinder, valve, and other similar components to ensure that internal leakage or external leakage would not develop into a dangerous condition.

15.2.5 Inspection and maintenance shall be taken for storage battery, driving motor, contactor and controller, limit switch, protection device, lead wire and connecting assembly, which shall be kept within safe operation condition. Special attention shall be paid to electrical insulation state.

15.2.6 Inspection for damage and leakage must be taken for exhaust gas system of internal combustion truck, adjustor of truckburetor, evaporator, and fuel injection pump.

**Notice: hazardous substances may be produced by the internal combustion engine in case of operation under close place. Sufficient ventilation is recommended in that condition.**

15.2.7 Check damaged condition of wheel tread, side face and wheel rim of the air-filled type pneumatic tire. Pressure of the tire that is specified by the manufacture must be kept. Gas in the tire shall be firstly be released before dismantling the air-filled type pneumatic tire from separable rim.

15.2.8 Check the bonded condition between solid tire and metal wheel band or wheel rim. Foreign matters on wheel tread of the tire shall be cleared if necessary.

15.2.9 Make sure that all the nameplates, indicator boards and labels (pattern) are clear and legible.

15.2.10 Inspection shall be taken for fuel oil system and auxiliary fittings to see if there is any leakage. Soap bath shall be used for leakage inspection of liquefied petroleum gas system. truck must leave the working site in case of any leakage in fuel oil system. And the truck cannot be put into operation until all the leakages have been repaired.

Inspection must be taken before reuse of all the dismountable liquefied petroleum gas containers or filling fuel into all the liquefied petroleum gas containers, to see whether there is the following

defective or damage:

- A) Dent, scuffing, flute;
- B) Damage of various valves or lever meters;
- C) Scraps in emergency valve;
- D) Damage or loss of emergency valve bonnet;
- E) Leakage at connection of valve and thread;
- F) Deterioration, damage, or loss of flexible seal at connections of gas filling or gas supply.

In case of occurrence of any defective or damage as above mentioned, no container would be allowed to be used before repair.

- 15.2.11 Neither modification in design nor addition to the truck shall be taken without permission of the manufacture for sake of weakening performance or operation security of the truck. Nameplate and instruction manual shall be revised accordingly in that condition.
- 15.2.12 Special purpose truck or equipment that is designed for dangerous condition, or is permitted to be used under dangerous condition, shall be paid special attention to, thus ensure the original safe operation performance of the truck.
- 15.2.13 All the components that are used for replacement must be of the same model, or at least of the same quality with the original part.
- 15.2.14 Industrial truck must be kept clean for sake of fire. Find loose or defective part in time. Keep clean for lifting device, truckrying device, wheel tread, foot pedal, and floor of the truck. No grease, oil stain, or other dirty substances shall be kept.
- 15.3 Inspection
- 15.3.1 If any potential defective, abrasion, or damage is found in the truck after inspection, which would threaten safe performance, effective measure shall be taken. Truck cannot be put into operation before repair.
- 15.3.2 Protective maintenance, lubrication and inspection shall be taken in accordance with schedule for the truck. Data that are in demand of record shall be truckefully kept.

