

A-3043/A-3040

Quick Start Guide

FULL ELECTRIC COUNTERBALANCE STACKER

Rated Load Capacity: 2,200lbs

Lifting Height: 98-118"



Scan the QR Code for more information.

Thank you for choosing our full electric counterbalance stacker.

For safe and correct use, please read this manual carefully and follow all instructions, precautions, and prohibitions. Keep this manual for future reference. Product specifications may change without notice. If there is any difference between this manual and the actual product, the product shall take precedence.

TABLE OF CONTENTS

INTRODUCTION

1. Warning
2. Parts Introduction
3. Installation Instruction
4. Inspection & Maintenance
5. Customer Support

1. WARNING

● Operating Environment

1. Operate this product only on hard, level surfaces.
2. Do not operate if the ambient temperature is above 104°F (40°C) or below 32°F (0°C).
3. Do not operate in flammable, explosive, or corrosive environments.
4. Do not operate inside cold storage areas.
5. Do not operate in rainy conditions.

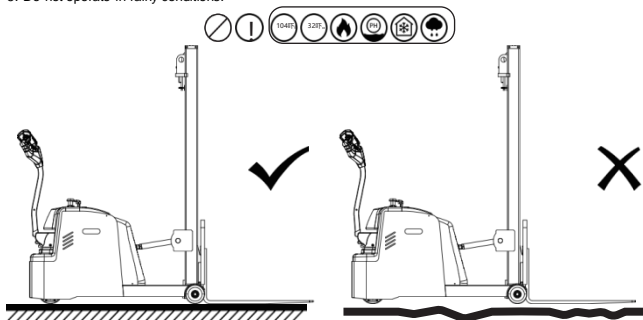

● Operational Guidelines

1. Personnel Safety

- Do not carry passengers.
- Keep all body parts, especially hands and feet, clear of the forks and moving parts.

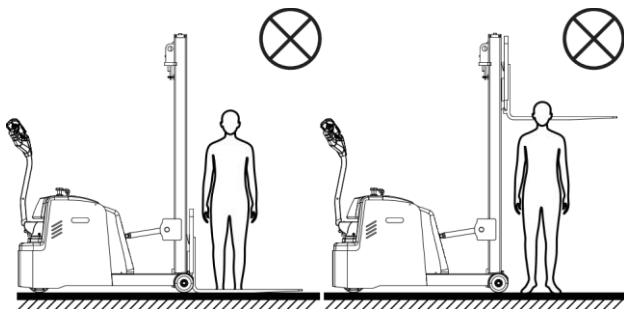

2. Load Limits

- Do not exceed the rated load capacity.
- Place loads securely in the center of the forks.
- Do not transport loose or unstable items.

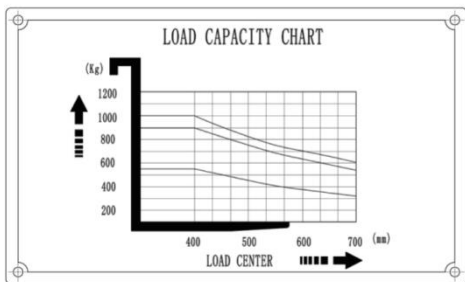
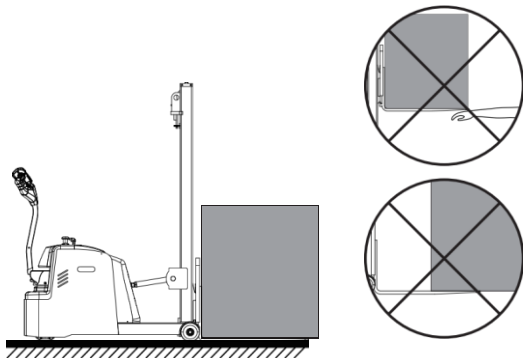

● Traveling and Lifting Guidelines

1. Starting and Traveling

- Wear safety shoes and ensure familiarity with all controls before starting the product.
- Pull the emergency stop switch and turn the key to the right.
- Sound the horn to alert nearby personnel before starting.
- Press handle down, Slowly rotate the forward/reverse rocker on the control handle to control the product's forward or backward speed and direction.

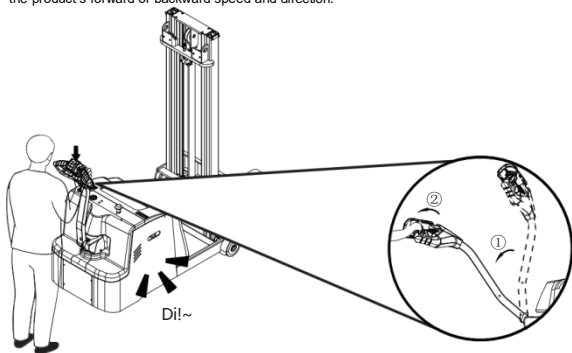

2. Braking

- Release the forward/reverse rocker. The product will automatically apply regenerative braking.
- Move the control handle to the vertical or horizontal position.
- The product will automatically engage electromagnetic braking.

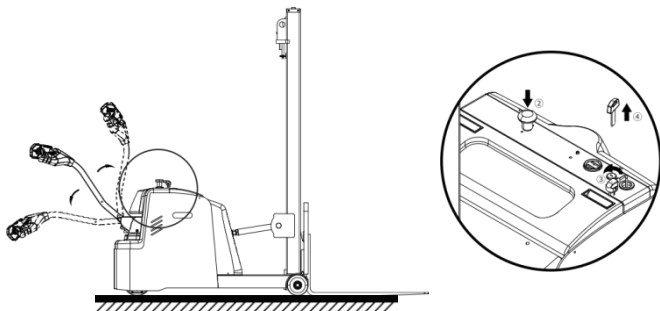

3. Lifting and Lowering

- Press the raise button on the control handle to lift the forks.
- Press the lower button on the control handle to lower the forks smoothly.

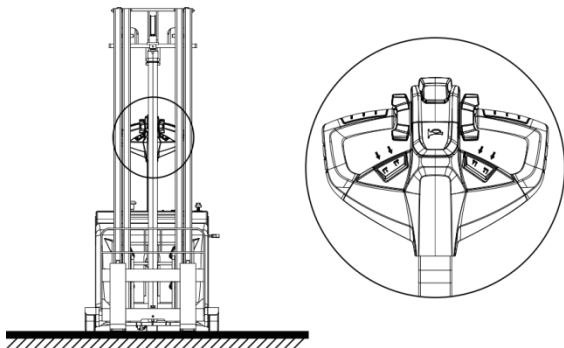

4. Tilting

- Press the tilt forward button on the control handle to tilt the forks forward for easier entry into the pallet.
- Press the tilt backward button on the control handle to tilt the forks backward to stabilize the pallet.

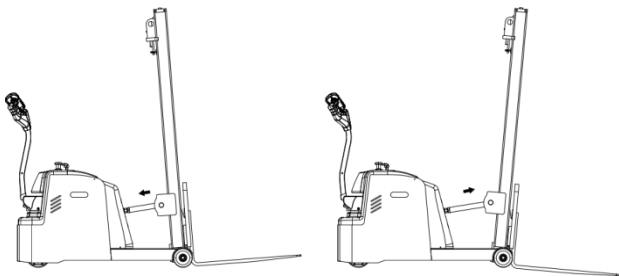

5. Ramp Operation

- When ascending with a load, keep the forks facing uphill.
- When descending, operate the product in reverse, keep the forks facing uphill, and control speed carefully.

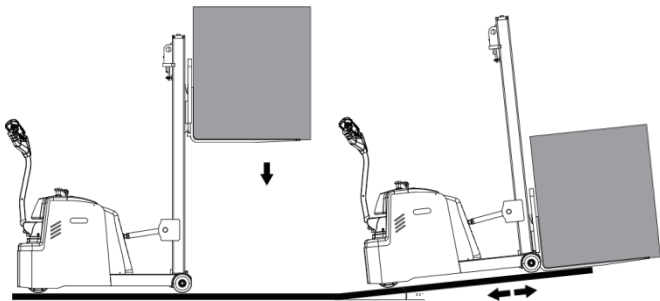

6. Charging

- Lower the forks and turn off the power.
- Charge the product in a well-ventilated area using the designated charger.
- The product is equipped with two lead-acid batteries and can be charged as needed.
- If the product is unused for more than one month, charge the battery monthly to maintain its performance.

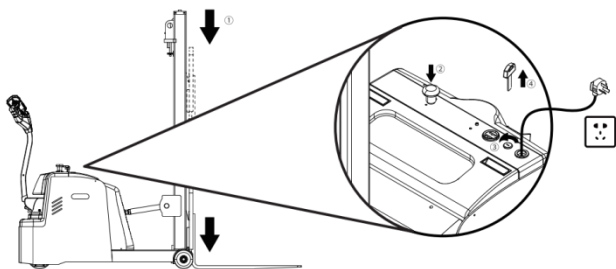

2. Parts Introduction

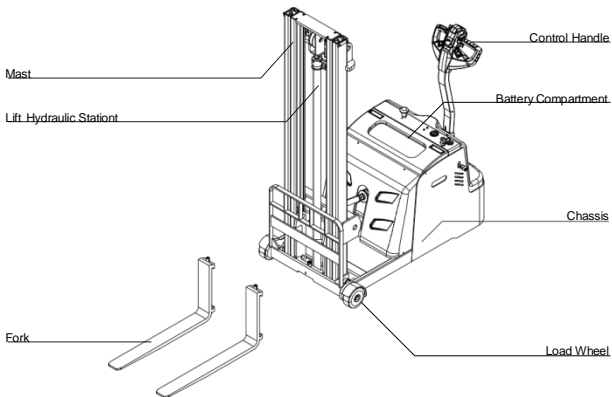
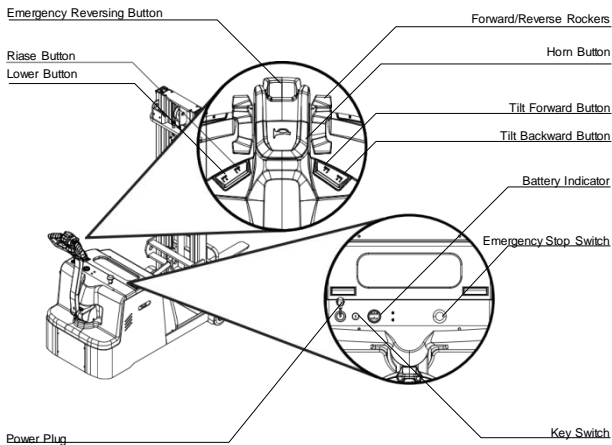

3. Installation Instruction

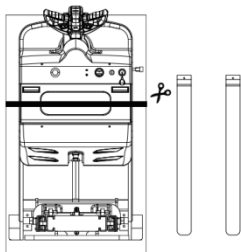

- ① Remove the outer packaging. Check for damage and verify accessories (manual, forks).
Cut the securing straps.

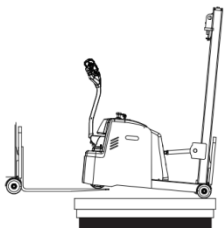

- ③ Optional unloading method 2 :
Lift the rear of the stacker with a forklift, remove the wooden blocks underneath, and carefully drive the unit off the pallet.

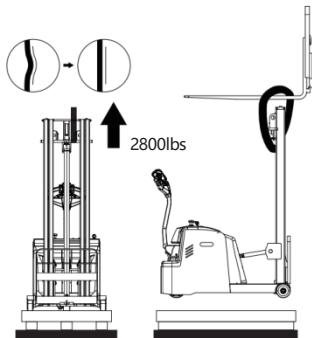

- Use slings (rated >2800 lbs) through the mast crossbeam. Lift the unit with a hoist or forklift, remove the pallet, and lower the unit safely to the ground.
- ②

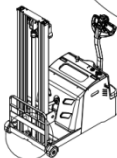
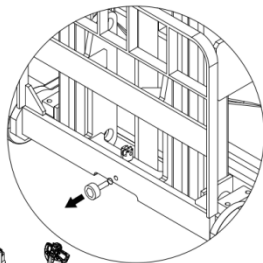

- ④ Remove the center limit bolt on the carriage.

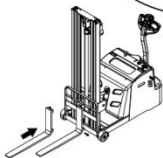
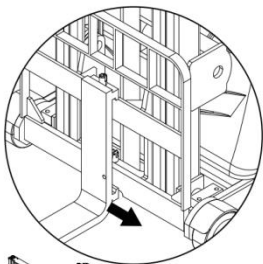

- ⑤ Insert the forks from the center and slide them to the desired positions on both sides.

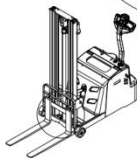
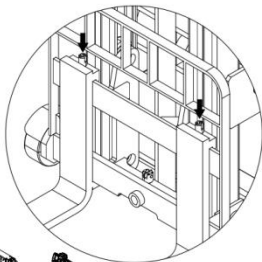

- ⑥ Tighten the side locking screws and reinstall the center bolt.

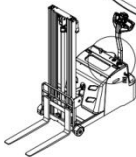
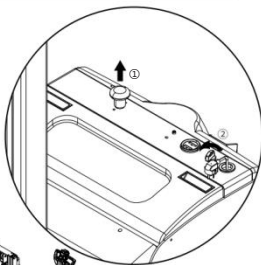

- ⑦ Pull out the Emergency Stop and turn on the Key. Lower the handle to the drive position.

Emergency Reversing Button

Forward/Reverse Rockers

Raise Button

Lower Button

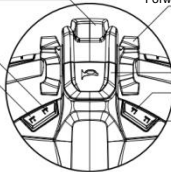

Horn Button

Tilt Forward Button

Tilt Backward Button

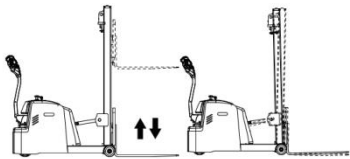

- ⑧ Test all functions: Throttle, Lift/Lower, Horn, Turtle Speed, and Tilt Forward/Backward.

4. Inspection & Maintenance

Conducting a thorough inspection of the product can help prevent malfunctions and ensure it achieves its expected service life. Maintenance hours are based on 8 hours of operation per day, 200 hours per month. For safe operation, the product should be inspected and maintained according to the maintenance schedule.

● 200-Hour Inspection and Maintenance

No.	Component	Inspection or Service
1	Overall Condition	Check for abnormalities in moving, fork lifting/lowering, and forward/backward tilting.
2	Oil Pipe & Cylinder	Check for leakage.
3	Drive Wheel	Inspect for wear and debris entanglement; replace if functionality is impaired.
4	Load Wheel & Bearing	Inspect for wear and debris entanglement; replace if functionality is impaired.
5	Frame & Fastener	Inspect for cracks; check if all fasteners are secure.
6	Control Handle	Ensure all buttons function correctly and verify the brake operates effectively within the operational range.
7	Key Switch & Emergency Stop Switch	Ensure proper operation.
8	Raise/Lower & Tilt	Ensure proper operation.

● Maintenance Intervals for Consumables and Components

Component	Inspection or Service	Interval (hours)
Load Wheel & Bearing	Replace	1,200
Drive Wheel	Replace	1,200
Seal	Replace	1,200
Gearbox	Change lubricant	1,000
Hydraulic Oil	Replace	1,000
High-Pressure Oil Pipe	Replace	2,000
Hydraulic Tank Filter	Clean	1,000
Drive Motor	Check functionality	1,000
Oil Pump Motor	Inspect brushes and bearings	1,000
Brake	Inspect brake pad wear	1,000
Fastener	Check all bolts and nuts for looseness	1,200

5. Customer Support

- Warranty Period

1. **New Product (Complete Unit):**

1-year warranty from the date of receipt.

2. **Spare Parts:**

3-month warranty from the date of receipt.

3. **Battery:**

6-month warranty from the date of receipt.

4. **Used Product (Complete Unit):**

3-month warranty from the date of receipt.

- Warranty Coverage

Complete product and its accessories.

- Non-Warranty Items

1. Wearable parts, such as wheels under normal use and fuses.
2. Damage caused by improper or incorrect operation.

1. **Main Sales-after: service@apolloliftus.com**

Main Customer Service: +1 888-801-3049

Working Hours: 9:00 AM to 5:30 PM