

CTD15R-E/N

Electric Pallet Stacker

- Operation Manual
- Parts Catalogue

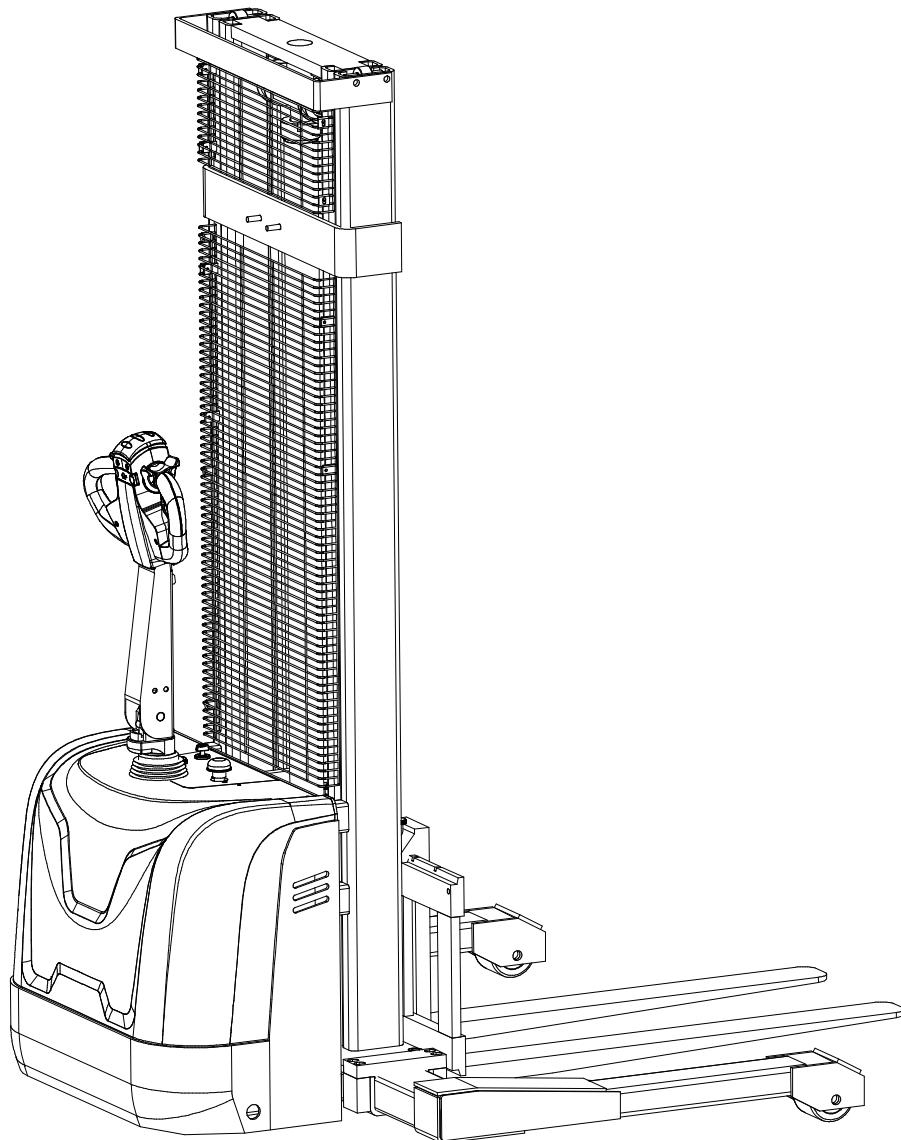

Hope CTD15R-E/N electric stackers will bring great convenience to your work!

- Please read the manual carefully before operation.
- This a common manual. We reserve the right to modify technology of the electric stacker. If there is anything in the manual that is not consistent with the actual stacker, the actual stacker should be considered correct and the manual is only for reference.

Warning!

Operators must strictly conform to ISO 21262:2020 "Industrial trucks — Safety rules for application, operation and maintenance". Untrained personnel are not allowed to operate the stacker.

According to ISO 21262:2020 "Industrial trucks — Safety rules for application, operation and maintenance", load capacity and lifting height of our CTD15R-E/N Electric Pallet Stacker are stipulated as follows:

1. When the lifting height of CTD15R-E/N stacker is below 3300mm (including 3300mm), the maximum load capacity is the rated capacity. Overloading is prohibited.
2. When the lifting height of CTD15R-E/N stacker is above 3300mm (excluding 3300mm), the load capacity is less than the rated bearing capacity. Take the following diagrams as a reference with the rated loads of 1500kg.

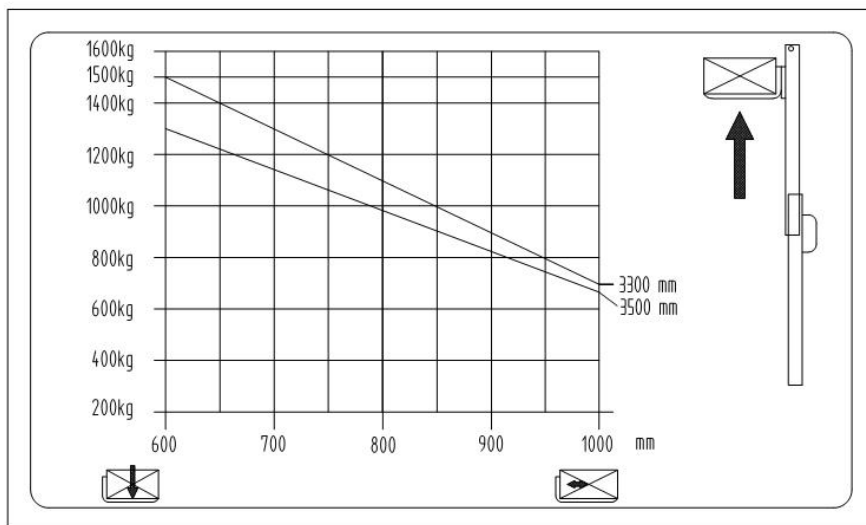

1.5T Load curve chart

Contents

Brief introduction	1
Description	1
1. Outline drawing	2
2. Brief introduction of the structure	4
3. Safety Norms	4
4. Initial operation	9
5. Use and operation instruction	10
6. Use, maintenance and charge of the storage batteries	13
7. Inspection before operation	14
8. Inspection after operation	14
9. Periodic maintenance and repair	15
10. The store, transportation and loading of truck	19
11. Replacement of storage battery	20
12. Common faults and troubleshooting:	20
13. Common fault signal and troubleshooting	23
14. Lists of accessories, spare parts and wearing parts	32
15. Structure diagram and principle diagram of the major parts	32
16. Packing list	35

Brief introduction

CTD15R-E/N electric pallet stacker is empowered by storage batteries and an AC motor. Traveling of the truck is made by gear transmission. Forks lift with/without loads by movements of the cylindered which is driven by an DC motor and hydraulic transmission. As the traveling and lifting of the stacker are electrically driven, it possesses the characteristics of energy saving, high efficiency, stable operation, easy operation, safety and reliability, low noise and no pollution, etc. The stacker adopts 24V storage battery, which greatly prolongs use time after one charging.

The stacker is applicable for goods piling and handling on hard and flat ground.

- **Allowed environment for using:**

- a) Height above sea level shall not be over 1000m;
- b) Ambient temperature shall not be higher than +40°C and no lower than -25°C;
- c) When the ambient temperature reaches +40°C, the relative humidity should not exceed 50%; at a lower temperature, higher relative humidity is allowed.
- d) Hard and flat ground
- e) It is prohibited to use the stacker in a flammable, explosive or corrosive environment with acid and alkali.

Description

The instruction manual shall be kept by the operator, and shall be read by the operator until he gets a full understanding.

The instruction manual is composed of correct operation, convenient and simple maintenance, and routine inspection.

The instruction manual shall be carefully read before operation, for purpose of correct drive and suitable maintenance to ensure safe and effective material transportation.



The instruction may be in disagreement with practical product due to product innovation.

The instruction manual shall be accompanied with in case of truck leasing or transfer.

Please come into contact with our sales department in case of any problem.

Description of symbol: Regulations of the following symbols are of great importance to your safety and others as well.

Please observe these regulations:

	Danger	Indicates an impending danger. Deaths or severe injuries would be resulted without any precaution or avoidance. You must observe those requirements.
	Warning	Indicates a potential danger. Deaths or severe injuries would be resulted without any precaution or avoidance. You must observe those requirements.
	Caution	Indicates a potential danger. Moderate injuries would be resulted without any precaution or avoidance. You must observe those requirements.
	Notice	You shall pay attention to statements that are in direct or indirect relation with personal security and truck maintenance.

1. Outline drawing

1.1 CTD15R-E/N Outline drawing

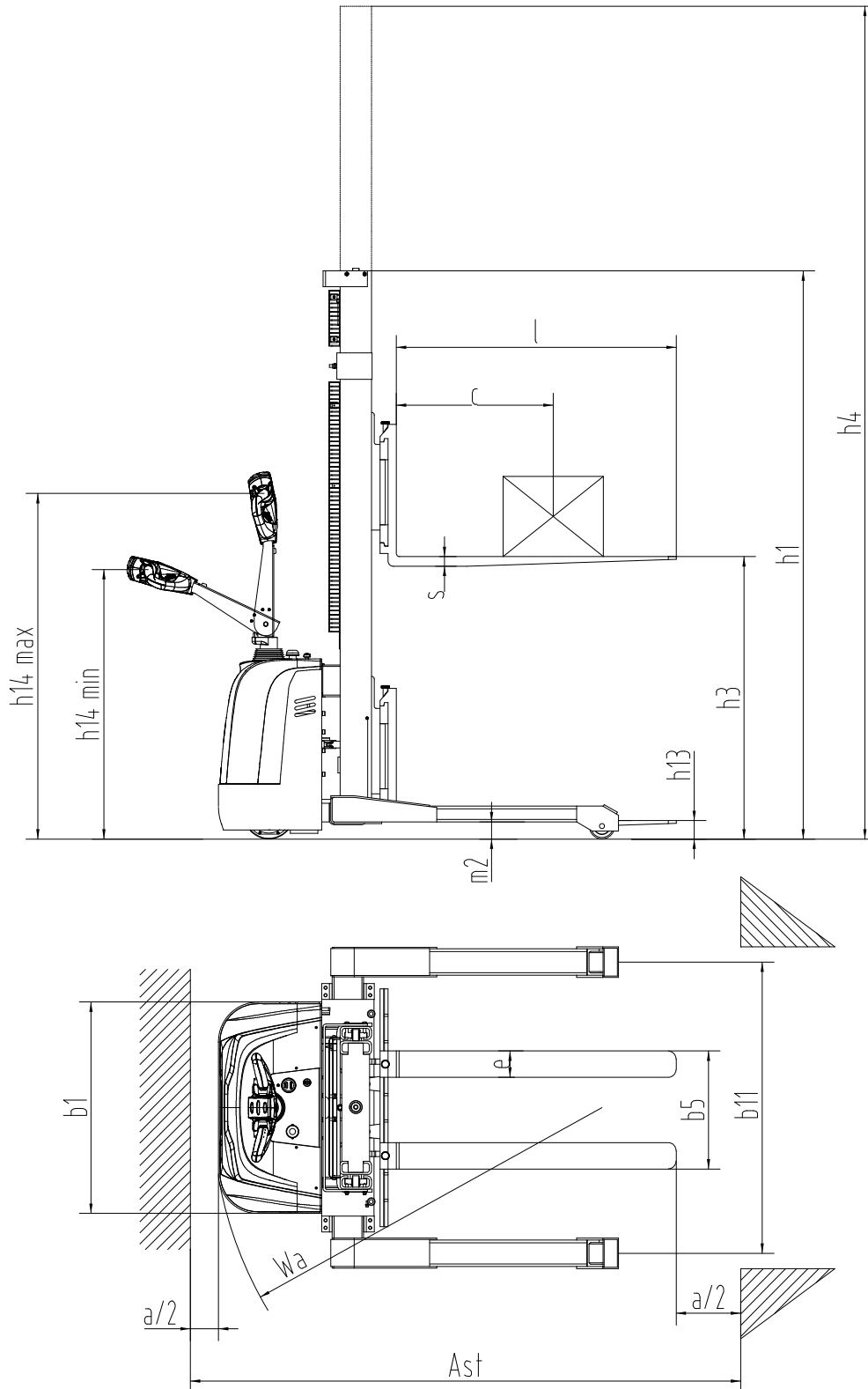

1.2 Main technical parameters

Characteristics	1.1	Manufacturer(abbreviated)		
	1.2	Manufacturer's type designation		CTD15R-E/N
	1.3	Drive: electric (battery type, mains, ...), diesel, petrol, fuel gas		Electric
	1.4	Operator type: hand, pedestrian, standing, seated, order-picker		Standing
	1.5	Rated capacity/rated load	Q (kg)	1500
	1.6	Load center distance	C (mm)	600
	1.8	Load distance, center of drive axle to fork	X (mm)	635
	1.9	Wheelbase	Y (mm)	1123
Weight	2.1	Service weight(battery incl.)	kg	635/655/665/675
	2.2	Axle loading, laden front/rear	kg	530/1140
	2.3	Axle loading, unladen front/rear	kg	485/185
Wheel chassis	3.1	Tyres: solid rubber, superelastic, pneumatic, polyurethane		PU
	3.2	Tyre size, front		φ195×70
	3.3	Tyre size, rear		φ98×82
	3.5	Wheels, number front/rear (× = driven wheels)		1x+2
	3.7	Tread, rear	b_{11} (mm)	1036-1436
Dimension	4.2	Height, mast lowered	h_1 (mm)	2145/1895/2145/2295/2395
	4.4	Lift	h_3 (mm)	1600/2500/3000/3300/3500
	4.5	Height, mast extended	h_4 (mm)	2145/3145/3645/3995/4145
	4.9	Height drawbar in driving position min./max.	h_{14} (mm)	880/1260
	4.15	Height, lowered	h_{13} (mm)	70
	4.19	Overall length	l_1 (mm)	1830 (1150 fork) 1750 (1070 fork)
	4.20	Length to face of forks	l_2 (mm)	680
	4.21	Overall width across chassis	b_1 (mm)	1155-1555/800
	4.22	Fork dimensions DIN ISO 2331	s/e/l(mm)	35/100/1070(1150)
	4.25	Fork spread	b_5 (mm)	200-800
	4.32	Ground clearance, centre of wheelbase	m_2 (mm)	65
	4.34.1	Aisle width for pallets 1000 × 1200 crossways	A_{st} (mm)	2230
	4.34.2	Aisle width for pallets 800 × 1200 lengthways	A_{st} (mm)	2210
4.35	Turning radius	W_a (mm)	1345	

Performance	5.1	Travel speed, laden/unladen	km/h	4.5/5	
	5.2	Lift speed, laden/unladen	m/s	0.09/0.15	
	5.3	Lowering speed, laden/unladen	m/s	0.15/0.11	
	5.8	Max. gradeability, laden/unladen	%	6/15	
	5.10	Service brake with load, deceleration		EM brake	
Motor	6.1	Drive motor rating S2 60 min	kW	0.65	
	6.2	Lift motor rating at S3 15%	kW	2.2	
	6.4	Battery weight	V/Ah	24/105	24/125
	6.5	Battery voltage / nominal capacity K ₅	kg	26X2	35X2
		Battery dimension	mm	260×168×217	330×171×217
Other	10.7	Noise level at operator's ear, according to DIN12053	dB(A)	70	

2. Brief introduction of the structure (ref.to the structure diagram and the principle diagram of major parts)

The stacker mainly consists of frame, mast, fork, lifting oil cylinder, operation handle, steering device, driving wheel, storage battery pack, hydraulic power unit and control system for electrical equipment, etc.

3. Safety Norms



Warning:

Please pay attention to the following items first before operation of the truck:

- 1) This electric truck is only limited to utilization indoor with a hard flat floor. Operation in inflammable, explosive environment or corrosive environment such as acid or alkaline condition shall be strictly forbidden.
- 2) Only drivers who have received formal training or are authorized can be allowed to drive the truck.
- 3) Read this instruction carefully before operation so as to master the performance of the stacker; check the truck whether it is in its normal condition before each operation. It is forbidden to use faulty stacker; repair by untrained persons is forbidden as well.
- 4) Overloading operation is forbidden.
- 5) As for goods carrying and operation, center of gravity of the goods must be within range of the two forks. It is forbidden to transport loose goods
- 6) The truck shall travels slowly when forks pass in or out of pallet.
- 7) It is strictly forbidden to press the lifting or lowering button during the traveling of the truck. Meanwhile, don't switch lifting and lowering buttons rapidly or frequently, because rapid and frequent lifting or lowering will cause damage to the truck and goods.
- 8) Don't load heavy goods on the forks rapidly.
- 9) Don't lay the goods on the truck for a long time!
- 10) It is strictly forbidden to make sharp turn on narrow aisle. When it is turning, slow down the truck so as to ensure the safety of personnel and goods.
- 11) Descend the forks to the lowest position when the truck is not used.
- 12) It is strictly forbidden to put any part of the body under heavy goods and forks.
- 13) This truck is suitable to be used on flat ground or flat platform. Don't put the truck on the slope for a long time.
- 14) Overloading operation is forbidden. Otherwise the wheel will skid, resulting in the damage of wheel

and motor as well as danger of the human body and goods.

15) It is strictly to use the truck under stipulated voltage of 20.4V.

16) It is strictly forbidden to conduct charge by connecting the plug to AC power directly.

17) It is forbidden to operate the stacker when the lift height of fork exceeds 500mm.

3.1 Safety operation norms:

1) Training of driver:



Notice

Even though each electric pallet stacker may have the same technical parameters, there may be differences on features of braking and acceleration as well. Never drive the truck until you get familiar with all those operations.

2) Wear of the driver during truck driving:



Notice

Please put on safety shoes and protective clothes. Do not wear clothes that are too loose for sake of being caught, which would result in danger.

3) Rules that must be observed:



Notice

Never drive the truck when you are tired or un-concentrated, with an injection of drug, or after a liquor drinking.

Safety rules and regulations shall be observed during operation or maintenance of the truck.

4) Safety of working place:



Notice

This kind of electric stacker is only limited to utilization indoor with a hard flat floor. Operation in inflammable, explosive environment or corrosive environment such as acid or alkaline condition shall be strictly forbidden.

a) Good roadway condition shall be kept and the traffic should be smooth.

b) Sufficient light ray shall be ensured on working place.

c) Fire extinguishing appliances shall be equipped in the places where truck and charging is operated. The extinguishing appliances shall comply with the requirements of extinguishing fire of solid combustible matter and electric apparatus.

d) The value of truck noise mentioned in instruction is measured under the condition of new truck running on flat, smooth and hard ground. If the traffic surface is bad or the tyre of truck is damaged, the noise may be amplified.

5) Integrity of the truck shall be realized:



Warning

Do not make modifications on the truck.

Please observe safety rules and regulations of your working place during operation, inspection, and maintenance of the truck.

Unauthorized truck modification is not permitted. No modifications or alterations to a powered industrial truck, which may affect, for example, capacity, stability or safety requirements of the truck, shall be made without the prior written approval of the original truck manufacturer, its authorized representative, or a successor thereof. This includes changes affecting, for example braking, steering,

visibility and the addition of removable attachments. When the manufacturer or its successor approve a modification or alteration, they shall also make and approve appropriate changes to capacity plate, decals, tags and operation and maintenance handbooks.

Only in the event that the truck manufacturer is no longer in business and there is no successor in the interest to the business, the user may arrange for a modification or alteration to a powered industrial truck, provided, however, that the user shall:

- a) Arrange for the modification or alteration to be designed, tested and implemented by an engineer(s) expert in industrial trucks and their safety;
 - b) Maintain a permanent record of the design, test(s) and implementation of the modification or alteration;
 - c) Approve and make appropriate changes to the capacity plate(s), decals, tags and instruction handbook;
 - d) Affix a permanent and readily visible label to the truck stating the manner in which the truck has been modified or altered together with the date of the modification or alteration, and the name and address of the organisation that accomplished the tasks.
- 6) Prepare safety operation procedure:
Safety operation procedure shall be formulated with consideration of practical situations before operation of the truck. Safety shall be taken into full consideration in preparation of the safety operation procedure.
- 7) Operation of truck under unsafe condition is strictly forbidden:
a) Operation under unsafe condition is forbidden, such as under conditions with uneven floor, or impeded road. Lifting on a slope is strictly forbidden.
b) Faulty truck is forbidden to use.
c) Make sure a daily inspection of the truck would be taken. Please immediately repair or replace in case of any abnormal conditions.
- 8) Overloading operation of truck is forbidden:



Warning

Overloading operation of truck is forbidden. Overloading operation would cause damage to the truck or bring harm to operator.

- 9) Use suitable pallet:
The pallet shall be of suitable dimensions, neither too wide nor too large.
- 10) Electrical system check:



Notice

Before checking the electrical system, turn off the key switches and the emergency isolation switches.

3.2 Safety Operation Specification:

- 1) Check the safety condition around the truck:



Notice

Before starting up the truck, please ensure that there is no person around it.



Notice

If the driver's view is shielded by the bulky goods carried, please drive backwards or drive under the guidance of other working personnel.



Notice

Ensure no people around the truck when driving backwards.



Notice

Driving through the narrow access shall be guided by working personnel.



Notice

At crossroad or other places impeditive for view, the driver shall not drive until there is no person at both sides.



Notice

Keep concentration when operating truck.



Caution

The driving mechanism of truck is installed on the foreside. Due to this difference from common trucks, the foreside of truck swings comparatively fast when turning around. For this reason, to prevent collision with other objects nearby the foreside of truck, do drive or turn slowly.

2) Strictly forbid harsh driving



Notice

Never start up, brake or turn abruptly.

Abrupt start-up or braking may cause the falling of goods.

Abrupt turning during traveling may cause the tilting of truck and result in serious accident. Do decelerate and take care to turn.



Notice

Observe all items of safety rules on working place. Decelerate and sound horn when travel by other truck or trucks. Avoid driving in places with bad view.



Notice

Ensure to provide certain clearance between truck and entrance.

3) Never drive too close to roadside.



Notice

Ensure to provide enough distance between the truck and roadside or platform edge.

When running on narrow road or platform, keep a certain safety distance with the edge against falling of the truck.



Warning

Avoid turning or loading and unloading operation on slope; otherwise the truck can go tilting.

3.3 Operation norms:



Notice

The truck can only carry goods under rated capacity.

- 1) Forbid overloading operation.
- 2) Forbid defective transportation.
- 3) Passengers on truck must be forbidden.
- 4) Never push or pull the handle abruptly
- 5) Never use the truck as towing truck.
- 6) When transporting over-wide goods, the driver shall be extremely careful to turn slowly to keep balance of the goods. Decelerate when ascent and descent, meanwhile, watch around for sake of safety.
- 7) The faulty truck for future repair must not be parked at places impeditive for traffic. Lower down the fork arms to the lowest position and put on the warning board. Pull off the key.
- 8) When protective devices such as protective cover of mast is not mounted, it is forbidden to operate the truck.
- 9) Take care to avoid the danger of wind force when loading goods.



Notice

Take care to avoid the danger of wind force when loading goods.

- 10) The operator shall master the traveling speed according to site condition. The truck shall slow down and move at a low speed when turning, at a narrow aisle, passing by swing doors or places where view impeded. And the truck shall keep enough distance with the forklift moving forward. Abrupt stop, sharp turn and overtaking are forbidden at dangerous places or where view is impeded except accidents. It is forbidden hold body or hands out of the driving cabin.
- 11) **Driver' s view during operation:** The driver' s view must keep in the traveling direction of the stacker and pay attention to the condition on driving roads at all times. If the goods carried impeding driver' s view, goods carried must be adjusted to the backward of driver' s view. If the goods can not be adjusted, another operator shall be arranged and walk by the stacker so as to report the forward road condition for the truck driver.
- 12) **Upgrade or downgrade driving:** The route of upgrade and downgrade shall be specified driving roads. The ground shall be kept clean, safe and reliable in accordance with technical performance of the stacker. When the truck is moving upgrade with goods, the forks should be kept in the forward position. While driving downgrade, the stacker shall move backward. Turning, tilting driving and parking is not allowed during upgrade and downgrade moving. Make sure to slow down when downgrade driving and always make prepare for braking.
- 13) **Driving the stacker to elevator or charging platform:** When it is necessary to drive the stacker to elevator or charging platform, make sure that elevator or charging platform has enough loading capacity, with the design structure applicable for bearing stacker. Meanwhile the elevator and charging platform should be permitted by the equipment user. Checks must be carried out before operation. Before driving into the elevator, the goods should be carried into the elevator first and

select the suitable parking space for the truck in order to avoid collision with walls during lifting. When there is other person needs to use the elevator, they should place the stacker at first. Then they can come into the elevator afterwards. When the elevator reaches the specified height, the personnel shall get out of the elevator at first.

- 14) **Conditions for goods to be transported:** The stacker operator should check the goods carefully make sure that there is not any risk. Before transportation of the goods, place and locate the goods. If there is any possibility of falling or overturning of the goods during transportation, it should be mounted with protective devices (such as protective guard).

3.4 Important notice after operation:

- 1) Parking: Park the truck at appointed place. Never park the truck on slope. Ensure the following points to be achieved before leaving away the truck:
 - a) Lay down the fork to the lowest position naturally.
 - b) Turn the steering wheel to the middle position.
 - c) Turn off the key switch.
- 2) Clean up the truck:



Notice

When cleaning up the electrical system, use compressed air but not water.

- 3) Charge:



Warning

Open flame is forbidden to appear at the charge places, otherwise, explosion or fire disaster can be caused.

Make a record of charge. As for the charge method, refer to the part about storage battery operation.

4. Initial operation

4.1 Initial operation:

- 4.1.1 In case of dangerous conditions, the power can be cut off, and the battery plug must be connected to the emergency parking plug of the stacker itself.



Warning

It is strictly forbiddent to operate the stacker without emergency parking plug.

- 4.1.2 The stacker can only be driven by the battery power, but without rectified AC current which may damage the electric parts of the truck. And length of battery cable (tow cable) shall not be over 6m.
- 4.1.3 If the stacker is driven by the external battery through a tow cable, it is forbidden to lift the loads.
- 4.1.4 Befor initial operation of the stacker, checks must be carried out as follows:
 - a) Check that whether the device is complete or whether the status is normal.
 - b) If the stacker has not been mounted with battery, it must be mounted with battery. Take care not to damage the battery cable.
- 4.1.5 The feature curve of charger shall be adjusted (charging curve) .
- 4.1.6 If the truck is not used for a long time, wheels placed on the ground will be pressed. Only after the truck is put into operation for a short time, the wheel can come to the original shape.

4.2 Drive of the stacker without the driver of the stacker itself:



Warning

It is strictly forbidden to drag the stacker on the slope.

- 4.2.1 In case of dragging stacker during emergency operation, the electromagnetic brake must be loosened.
- 4.2.2 When the stacker is placed at a specified place, the electromagnetic brake must be relocated so as to make the stacker in a state of brake.

5. Use and operation instruction

The electric pallet stacker adopts storage batteries as the dynamic source for short distance goods handling and stacking. Correct use and operation will bring great convenience to your work but incorrect use and operation will damage the stacker or pose risk to you and your goods.

5.1 Before operation:



Warning

It is strictly forbidden to use any faulty truck.

- 5.1.1 Before operation, please check if the truck is in normal condition: Is there any oil leakage in the hydraulic pipes? Are the supporting wheels able to operate normally? Is there any block? The trucks with problems are prohibited for operation.
- 5.1.2 Check if there is any electric power in the batteries with the method indicated in Fig.1. Pull the general power switch out to turn on the general power supply, unlock the electric lock on the handle, check the electric energy meter on the instrument panel of the truck. If the zero end grid is bright, it indicates there is no electric power in the batteries and charging should be conducted at once. It is prohibited to operate the truck without electric power as that will greatly reduce the service life of the batteries and even damage the batteries.

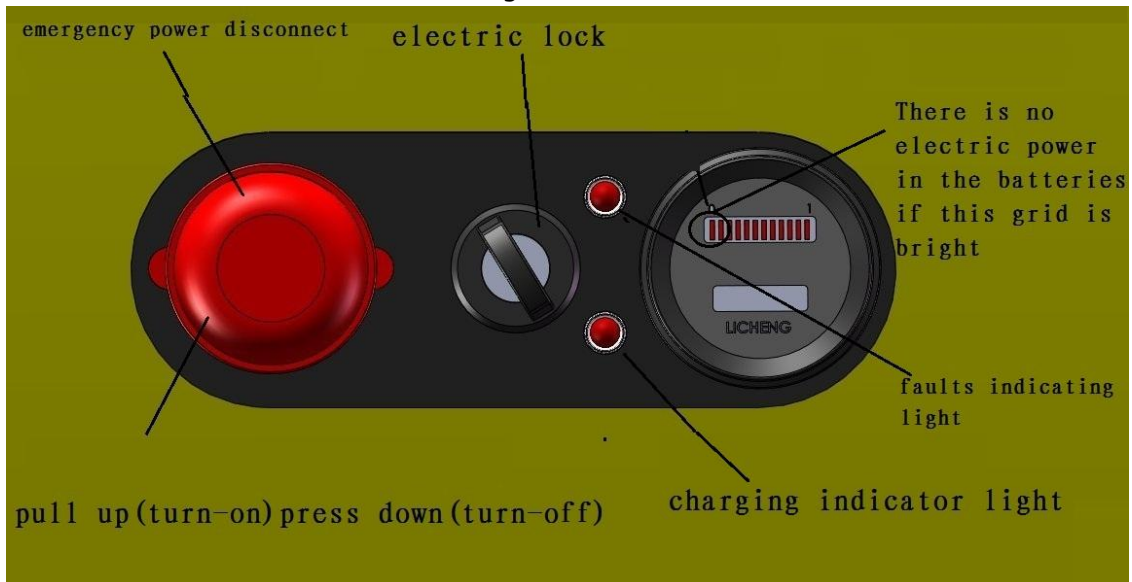

Fig.1

- 5.1.3 Check if the truck brake is normal. Check the lifting, dropping, forward and backward traveling of the truck to see if the actions are normal. Check if the emergency reverse action of the truck is normal with the method indicated in Fig.2:

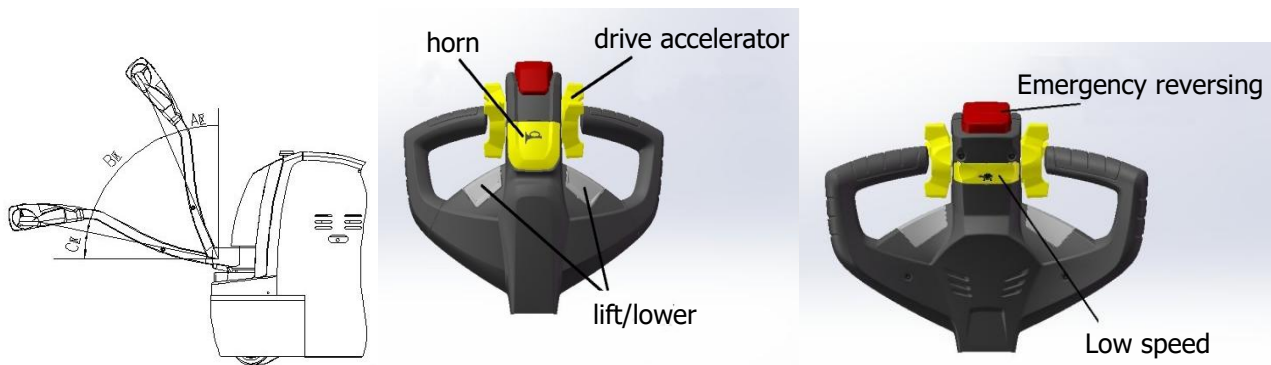

Fig. 2



Warning

It is strictly forbidden to turn the accelerator knob fastly to speed up the stacker abruptly during goods transportation.

Move the control handle to division A or division C as indicated in Fig.2 and press the rise/lowering button on the control handle to see if the lifting and lowering of the fork is normal. Then turn the control handle to division B as indicated in Fig. II, slowly start the truck and press the handle to the horizontal position to check that whether the truck can travel and brake normally.

Move the control handle to division B as indicated in Fig.2, press the emergency reverse button on top of the control handle to check that whether the truck can travel backward normally.

After the above check, if there is no failure in the truck, it can be put into operation; if there is some failure, please repair it at once. It is prohibited to use trucks with problems.

5.2 In operation

5.2.1 Accelerator knob: The accelerator knob is used for controlling traveling direction and speed of the stacker. When it is for the traveling operation, turn the operation handle to B area indicated in the above diagram. When the handle is in A or C area, the stacker is in a power-off status, and can not travel. When the operation handle is in B area and the accelerator knob is turned in one direction, the stacker will travel in that direction. While the accelerator is turned in another direction, the stacker will travel in another direction. Meanwhile the bigger the turning amplitude is, the faster the truck will travel.

Note: A side-magnetic brake is installed on the shaft end of the driving wheel motor and there is a cam and an inching switch installed on the rotary shaft of the rotary arm. Only when the rotary arm is at $45^{\circ} \pm 35^{\circ}$ (as indicated in Fig. II), the stacker can be turned on and travel. Larger or less than the angle, the stacker will be powered-off and braked. In that case, the stacker can lift goods. When lifting goods, the stacker cannot travel. As indicated in Fig. II, when the operation handle is in division A or division C, the stacker can only lift or lower but not travel; when the control handle is in division B, the stacker can travel as well as lift or lower. The operation position of the handle will not be specially described in the following descriptions, i.e. the stacker can only lift or lower but not travel when the handle is in division A or C and the handle must be in division B when the stacker is traveling.

5.2.2 As indicated in Fig. II, there is a button on the operation handle which is used for slowing down the stacker. When this "slow down" button is pressed as well as accelerate knob is turned, the stacker will travel at a low speed. This state is best suitable for turning a corner, stacking and moving into and out of the shelf while taking goods. When the "slow down" button is released and the accelerate knob is turned, the stacker will travel at a normal speed.

5.2.3 Operation of handling and stacking:



Notice

Please check the following items before operation of the stacker:

Ensure no goods falling and goods damaged at loading and unloading area.

Ensure no goods or objects impeding for safety.

As indicated in Fig. 2, pull out the general power supply switch, unlock the electric door lock, and drive the stacker to the goods pile nearby. (The tip of the fork is 300mm from the goods pile). Press the lowering button, adjust the height of the fork to a proper position, and insert the fork slowly and as deep as possible into the pallet of the goods. Press the lifting button till the fork is 200-300mm from the ground. Drive the stacker to the location of the goods shelf and stop slowly. (The tip of the fork is 300mm from the goods shelf.) Press the lifting button and the fork rises to a proper height with the shelf (The bottom of the pallet is about 100mm higher than the goods shelf). Move the goods slowly to the accurate position of the shelf and press the lowering button to put the goods carefully on the shelf. Take the fork away from the goods and drive the stacker slowly to make the fork out of the goods pallet. (The tip of the fork is 300mm from the goods shelf.) Lower the fork until it is 300mm from the ground and drive the stacker away from the shelf. Attention should be paid to that there should be no obstacles around and when turning, the speed should be reduced.



Caution

The driving mechanism of truck is installed on the foreside. Due to this difference from common trucks, the foreside of truck swings comparatively fast when turning around. For this reason, to prevent collision with other objects nearby the foreside of truck, do drive or turn slowly.

5.2.4 Operation of taking goods off the goods shelves:

As indicated in Fig. II, pull out the general power supply switch, unlock the electric door lock, and drive the stacker to the goods shelf nearby. (The tip of the fork is 300mm from the goods shelf). Press the lowering button, adjust the height of the fork to a proper position, and insert the fork slowly and as deep as possible into the pallet of the goods. Press the lifting button to lift the goods till the bottom of the pallet is 100mm from the goods shelf. Slowly drive the stacker and slowly move the goods out of the shelf (the tip of the fork is 300mm from the goods shelf). Press the lowering button and the fork lowers to a height of 200-300mm from the ground. Drive the stacker away from the goods shelf until it reaches a desired position and then slowly stop it. Press the lowering button to put down the goods, make the fork completely away from the goods and move the fork slowly out of the goods pallet.

5.3 Abnormal situation handling during operation:

- 5.3.1 When pressing the lifting button, the fork can rise but when releasing the lifting button, the fork is still rising. The stacker is in a situation of out of lifting control. In that case, turn off the general power supply switch to cut off the power supply at once. Drive the stacker to a safe position to lower the fork manually and repair the circuit of the stacker.
- 5.3.2 If the brake is out of function when the stacker is in operation, the operation must be stopped at once and repair the stacker.
- 5.3.3 When the stacker is moving forward and pushing the operator against a wall or other objects, press the emergency reverse button on top of the operation handle and the stacker will automatically move backward to avoid injuring the operator.

5.4 After operation:

After operation, the stacker should be parked in a fixed parking position and routine maintenance should be conducted according to the stipulations in clause 6 and charging should be carried out.

6. Use, maintenance and charge of the storage batteries

● Charging method:

Either on-board charger or external charger is optional.

- a) **On-board charger:** Charging starts several seconds after connecting the plug to the 2-phase AC power supply.
- b) **External charger:** Charging starts seconds after connecting the connectors of the charger and the truck together, then insert the charger plug into a 2-phase AC power supply.



Warning

There is hydrogen gas accumulated in the battery case during charging. Thus the charging environment requires good ventilation and there should be no flame, otherwise explosion or fire may occur.

6.1 Initial charge

Initial charge should be conducted for batteries that have never been used

6.2 Use and maintenance

- 6.2.1 In order to guarantee the service life of the batteries, the batteries in use should be fully charged. Insufficiently charged batteries must not be used. During the process of use, close attention should be paid to the discharge extent. Over discharge is prohibited.
- 6.2.2 The batteries in normal use should avoid over-charge, but over-charge must be properly
- 6.2.3 conducted for the batteries in following situations, i.e. equalizing charge.
 - a) The "lag-behind" batteries--- batteries with a voltage lower than that of the other batteries in the discharging process and the batteries having been repaired for failure. (When equalizing charge is conducted, the positive and negative poles of the "lag-behind" battery should be respectively connected with the positive and negative ends of the charger, the DC power supply, and the charge should be conducted independently.)
 - b) Equalizing charge should be conducted for the batteries in normal use every 2-3 months.
 - c) Equalizing charge should be conducted for the batteries that have not been used for a long period of time before use.

6.3 Storage

Batteries should be stored in a clean, dry and well ventilated warehouse with a temperature of 5-40°C. The valid shelf life is 2 years. The batteries should be kept according to the following requirements during storage:

- a) No direct sunshine on the batteries and at least 2m away from heat source.
- b) Avoid contacting with any harmful substances. No metallic matters are allowed to drop into the batteries.
- c) The batteries should not be placed upright down and should not be impacted mechanically or heavily compressed.
- d) The batteries must not be stored with electrolytic solution. When it is required in special situation that the batteries must be stored with electrolytic solution, the batteries should be fully charged and the density and the liquid surface of the electrolytic solution should be adjusted to the stipulated values. When the storage period comes to one month, the batteries should be complementarily charged with the common charge method.

6.4 Charger

If the charger is full automatic type. It must meet with the following 2 requirements:

- a) The output voltage of charger: 24V
- b) The output current of charger (storage battery) : 20A

7. Inspection before operation

For the sake of safety operation and good situation of the electric truck, it is compulsory to check the truck completely before operation. Contact the sales department of our company when founding problems.

● Check point and check content:

	No.	Check point	Check content
Braking system	1	Operation handle	When the operation handle is turned, with the handle switching between area A and B, there is a noise from the brake.
	2	Brake clearance	The clearance between brakes should be kept between 0.2mm and 0.8mm.
Steering system	3	Operation handle	Degree of tightness and rotary flexibility.
Hydraulic system	4	Oil pipe	Leakage or not.
	5	Hydraulic oil	Appropriate oil quantity.
	6	Lifting oil cylinder	Whether there is any oil leakage.
Wheels	7	Pins, screws and all the fasteners	Check all the fasteners of the truck's wheels, i.e. pins or screws, loose or not.
	8	Wearing status	Compare the parameter lists; replace the wheel when its diameter reduces by 5%.
Storage battery	9	Charge	Confirm the display state of the battery capacity.
	10	Electrolyte	The solution level and density of electrolyte.
	11	Connecting line	The connecting line and socket shall be firm.
Horn	12	Horn	Press down the horn button to check whether the horn sounds.
Instrument	13	Function	Turn on the switch of electric lock to check whether the instrument displays normally or not.
Others	14	Structural part like truck frame	Check that whether lifting, lowering, forward & backward movement and emergency reverse of the truck is normal, and if there is any abnormal noise.
		Function	

8. Inspection after operation

After operation, the smudge on truck shall be wiped out. Besides, the following check shall be carried out:

- 1) Keep visibility of all graphics context marks such as warning signs, nameplates and notice board. These marks are able to instruct, caution and warn the operator to some degree.
- 2) The situation about deformation, distortion, damage or breakage
- 3) Add lubricating oil and grease if necessary.
- 4) Replace faulty components.

9. Periodic maintenance and repair

Comprehensive check for truck can avoid malfunction and ensure the service life. The hours listed in maintenance procedures is based on the cases that the truck works for 8 hours per day and 200 hours per month. For the sake of safety, maintenance shall be carried out according to maintenance procedure.



Notice

All the repair work shall be carried out by professional personnel.

Please contact the sales department of our company if you need to adjust or replace the components.

9.1 Precautions during maintenance:



Notice

The components for replacement shall be produced completely by our company. When replacing components of the truck, the components with the same safety requirement with the original design shall be used.

The lubricating oil and hydraulic oil in use shall be recommended by our company.

1) Places for maintenance:



Notice

The places for maintenance shall be appointed and can provide other services such as hoisting and safety protection facility etc.

The places shall have level ground and good ventilation.

The places shall be equipped with fire-extinguishing devices.

2) Before service maintenance matters needing attention:



Notice

No smoking.

Arrange the self-protection work.

Wipeout the effusive oil in time.

Before adding lubricating oil, clean up the dirty oil or dust on the joint with brush or cloth.

Except certain situation, turn off the key switch and pull off the power socket.

Lower down the fork arms to the lowest point when carrying out maintenance.

Ensure no goods on the truck when demounting the high pressure oil pipe. Besides, the fork arms shall be descended to the lowest position, by this way, the pressure of hydraulic system can be released.

For the reason that there are capacitors storing a little amount of electric energy in circuit, so before contacting the binding post of the main circuit, discharge at first.

Clean the electric section with compressed air, never flush with water.

When the truck requires high-position maintenance, the altitude safety protection must be carried out for the repairing and maintenance personnel.

9.2 Inspection and maintenance before the new truck put into operation

In order to follow the industry related regulations and ensure the absolute security to the truck in the transportation, for new ex-factory truck, it is possible that there is no electrolyte inside storage battery before the first use (except the inland sale).

The electrolyte of storage battery is prepared well before the truck leave the factory, and it is filled

into the storage battery by the professional personnel before the first use. First, place the truck to the site with good ventilation, open the lid of storage battery box, and open all the top plastic lids of storage battery. The plastic pot with storage battery electrolyte inside is raised using plastic funnel, and the electrolyte is poured into the storage battery in a slow way until the liquid level can be seen. After all the storage battery is filled, conduct initial charge to the storage battery timely according to the operation requirements of initial charge 6.1.

9.3 Daily inspection

1) Check the hydraulic oil level:

Lower the fork to the lowest, and add fuel with a lifting height of 2.5 meters (6L), 3 meters (7L), 3.3 meters (8L), and 3.5 meters (8.5L). Select recommended hydraulic oil brand.

2) Check the battery level;

Refer to the use and maintenance of batteries.

9.4 The inspection according to the need

1) Clean the truck

2) Inspect and screw down each fastener

3) Inspect the damage state of wheels

9.5 The inspection and maintenance after 50 hours(Weekly)

Braking system	1	When the operation handle is turned, with the steering handle switching between area A and B, there is a noise from the brake.
	2	The oil dirt and dust on the turning gearwheel should be cleaned.
	3	The clearance between brakes should be kept between 0.2mm and 0.8mm
Capability of electrolyte	4	Inspect the liquid level of electrolyte, pure water can be used for supplement if the liquid level is too low.
Density of electrolyte	5	The specific gravity should be 1.28g/ml after charged.
Clean the storage battery	6	Cover the lid, and flush with tap water.
Inspect the contactor	7	Burnish the coarse surface of contacts using sand paper.

9.6 The inspection and maintenance after 200 hours (Monthly)

Besides the weekly maintenance, the following maintenance should be carried out, and when the parts must be adjusted and replaced, please contact with maintenance personnel of our company. (keep monthly maintenance record)

	No.	Check point	Check content
Whole truck	1	Whole status	Abnormal or not.
	2	Horn	Sound
Steering system braking system hydraulic system lifting system	3	Operation handle	When the operation handle is turned, with the handle switching between area A and B, there is a noise from the brake.
	4	Brake clearance	The clearance between brakes should be kept between 0.2mm and 0.8mm.
	5	Operation handle	Degree of tightness and rotary flexibility.
	6	Truck frame and fastener	Function, and check cracks, lubrication and tightness of fasteners.

	7	Connecting rod and wheel carrier	Function and check the cracks, bending, deformation and lubrication condition.
	8	Oil pipe	Whether oil pipes leak or not.
	9	Hydraulic oil	Proper quantity of oil.
	10	Lifting oil cylinder	Whether there is any oil leakage or not.
electric system	11	Electrolyte	Liquid level, specific gravity and cleanness
	12	Plug	Function, whether it is damaged or not
	13	Key switch	Function
	14	Contactors	Contact performance and function
	15	Inching switch	Function
	16	Controller	Function
	17	Driving motor	Wearing status of carbon brush and selenium rectifier.
	18	Lifting motor	Wearing status of carbon brush and selenium rectifier.
	19	Steering motor	Wearing status of carbon brush and selenium rectifier.
	20	Fuse	Whether it is perfect or not
	21	Wiring harness and connection terminals	Whether flexible and whether damaged or not.

● **Adjustment of the brake clearance**

- 1) The structure of brake is shown as the figure. After a period of use, performance of the brake will decline due to the wearing and tearing of the brake plate. Then it is necessary to adjust the clearance of the brake. As indicated in the drawing, first use the insert ruler to check the clearance between the brake plate and magnetic steel. If the clearance is over 0.5mm, adjust it. Before the adjustment, clean the dirt and dust on the friction plate. During adjustment, first loosen the fitting screw
- 2) Then adjust the length of the adjustment screws 1 and screw down the tightening screws. After the adjustment, the clearance between brake plate and magnetic steel shall be kept between 0.2-0.3mm. During the adjustment, make sure that the three tightening screws are adjusted evenly so as to ensure that the clearance between brake plate and magnetic steel are distributed around equally. After the adjustment, turn on the brake with 24v DC power. Then the brake will make clear sound.

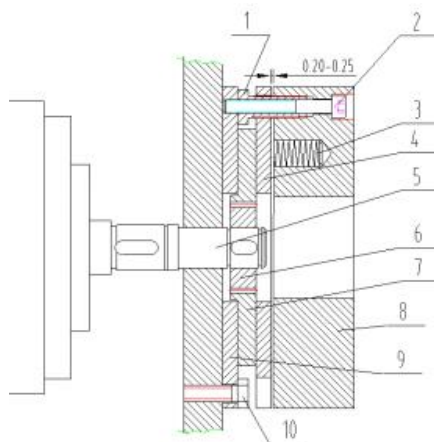

1. Hollow screw	2. Fitting screw	3. Spring	4. Armature
5. Motor shaft	6. Spline housing	7. Friction plate	8. Electromagnetic coil
9. Mounting cover plate	10. Mounting screw		

9.7 Maintenance for 600 hours(every three months)

During the maintenance every three months, the monthly maintenance process shall be repeated. When the parts must be adjusted and replaced, please contact with maintenance personnel of our company.

Contactor	Burnish the coarse surface of contacts using sand paper.
	Replace according to the status when the function is not well.
Motor	Wearing status of carbon brush and selenium rectifier.
Brake	Clean the dirt and dust on friction plates of the brake, meanwhile check the wearing status of the friction plates.

9.8 Maintenance for 1200 hours(every six months)

During the maintenance for a half year, the maintenance process for three months shall be repeated. When the parts must be adjusted and replaced, please contact with maintenance personnel of our company.

Contactor	Burnish the coarse surface of contacts using sand paper.
	Replace according to the status when the function is not well.
Motor	Wearing status of carbon brush and selenium rectifier.
Decelerate box	Replace the gear oil
Oil filter	clean
Brake	Clean the dirt and dust on friction plates of the brake, meanwhile check the wearing status of the friction plates.
Hydraulic system	Replace hydraulic oil. Check that whether there is any leakage in the lifting cylinder or not and replace the seals when necessary.
Fork wheel and bearings	Check the wearing condition, and replace them if necessary

9.9 Recommended working medium:

1) Hydraulic oil:

a) When it is normally loaded, we advise:

Hydraulic oil: LHPISOVG46, in accordance with standard DIN51524T.2, the average sustained temperature should between 40°C- 60°C.

b) When it is over loaded, we advise:

Hydraulic oil: LHPISOVG68, in accordance with standard DIN51524T.2, the average sustained temperature is above 60°C.

c) When it is lightly loaded with low temperature, we advise:

Hydraulic oil: HLPISOVG32, in accordance with standard DIN51524T.2, the average sustained temperature is below 60°C.

d) At the occasion with variable loading, we advise:

All the working conditions mentioned above can use the hydraulic oil LHPISOVG46 in accordance with standard DIN51524T.2 for replacement. The viscosity of this lubricant is very high (mostly used hydraulic oil).

If it is difficult to buy hydraulic oil, SAE20W/20 engine oil can be used to substitute HLP68 hydraulic oil.

2) Gear oil:

Hyperbola gear oil 85W-90(GL-5)

3) Lubricating grease:

3#Lithium grease

All kinds of depleted hydraulic oil, gear oil and grease will pollute the environment. For this reason, recycle the replaced working medium or treat according to local pertinent regulations

9.10 Maintenance period of consumables and partial parts:

Items	Maintenance content	Maintenance period	Remarks
Bearings of fork wheel	Replacement	1200 hours	
Fork wheel	Replacement	1200 hours	
Seals	Replacement	1200 hours	Replace when finding out damage
Gear box	Replacing lubricant grease	1000 hours	
Hydraulic oil	Replacement	1000 hours	
High pressure oil pipe	Replacement	2000 hours	Replace when finding out damage
Strainer of hydraulic reservoir	Cleaning	1000 hours	
Driving motor	Check for carbon brushes and bearings	1000 hours	
Steering motor	Check for carbon brushes and bearings	1000 hours	
Oil pump motor	Check for carbon brushes and bearings	1000 hours	

10. The store, transportation and loading of truck

10.1 The store of truck

If the electric pallet stacker is not used for over two months, it should be placed in the room which is in good ventilation, no frost, clean and dry; also the following measures should be taken:

- 1) Clean the truck thoroughly.
- 2) Lift the forks completely for several times, check it is normal or not.
- 3) Lower the forks to the lowest position.
- 4) Support the side near to driver of truck with square timber to lift the driving wheels of truck from the ground.
- 5) Apply a layer of flimsy oil or grease on all the bared surface of mechanical parts.
- 6) Lubricate the truck.
- 7) Check the status of storage battery and electrolyte, and imbrue the non-acid lubricating grease to the binding post of storage battery.
- 8) All the electrical contacts should be sprayed using appropriate contacts spray.

10.2 Transportation of truck

If the truck needs to be transported for a long distance, support the side near to driver of truck with square timber to lift the driving wheels of truck from the ground. The two front wheels of truck shall be fixed stably by sphenoid wood block. Fasten the truck to transport truck with ropes.

10.3 Loading and unloading of truck

Before loading the truck, check out the nameplate for the total weight of truck to choose appropriate hoisting handling equipment. The hoisting of truck shall be kept level, and landing shall be kept slow and stable. The personnel around shall watch for safety. One of the personnel is responsible for conducting. If the other truck is used for loading and unloading, please watch the bottom situation of the truck. Take care to insert the fork arms to the bottom, in avoidance of damaging the driving wheel, balance wheel and forward wheel.

11. Replacement of storage battery

The steps to replace the battery are:

- 1) Turn off the truck's power.
- 2) Unscrew the cover's fixing screws.
- 3) Remove the battery pressure plate by unscrewing its fixing screws.
- 4) Disconnect the power and control cables.
- 5) Take out the battery.
- 6) Install the new battery in reverse order.



Notice

Handle the storage battery gently during hoisting and transportation of the battery. Otherwise it will cause damage to the battery or bring danger to human body.

12. Common faults and troubleshooting:

No.	Faults	Possible causes	Trouble shooting
1	The stacker can not start.(The contactor does not work either)	1) The fuse of control circuit is burnt out.	Replace
		2) The power switch is in poor connection or is damaged.	Repair or replace
		3) Fuse of main circuit is blown.	Replace
		4) The switch of electric lock is in poor connection or damaged.	Repair or replace
		5) The connection of the storage batteries is loose or has fallen off.	Tighten
	The stacker can not start.(The contactor works.)	1) The side-magnetic brake of the drive wheel does not suck and the stacker is in a braked condition.	Repair or replace
		2) The walking motor carbon brush is worn or bad contact between the steering device and the carbon-brush.	Repair or replace
		3) The magnet-exciting coil of the stepper motor is broken or bad contact at the wire end.	Repair or replace
		4) Bad contact.	Repair or replace
		5) There is a trouble at the MOSFET tube type circuit board.	Repair or replace
2	The stacker can only move forward or backward.	1) The contactor is in poor connection or burnt out.	Repair or replace
		2) There is malfunction in circuit board.	Repair or replace
3	The stacker can not stop during traveling.	Broken contact. The moving contact cannot be reset.	Cut off the power at once and replace the contact

4	The brake does not work	1) The erection bolt of the fine motion switch looses or is damaged.	Adjust or tighten the bolt or replace the fine motion switch.
		2) The connecting wire of the side-magnet brake is loose or damaged	Tighten the bolt or repair the side-magnet brake.
		3) The braking plates of the side-magnet brake are worn.	Replace the braking plates.
5	The steering has got stuck	1) The bearing of the steering device is damaged.	Replace the bearing
		2) The bearing of the steering device lacks lubricant or there is too much dust	Clean the bearing
6	Difficult steering of the drive wheel, noise and the motor is overloaded.	1) The gear or bearing has got stuck because of foreign matters.	Clean or replace the bearing
		2) There is a gap in the bearing installed	Adjust the clearance
		3) The front wheel bearing is damaged.	Replace the bearing
7	The forks cannot be lifted.	1) Overload	Reduce the load
		2) The pressure of the overflow valve is too low	Adjust the pressure higher
		3) Internal abnormal leakage in the lifting oil cylinder	Replace the seals
		4) Insufficient hydraulic oil	Add appropriate quantity of filtered hydraulic oil
		5) Insufficient voltage of the storage battery	Charge the battery
		6) The control handle is not horizontal or vertical, the oil pump motor has not been turned on.	Improper operation
		7) Damaged oil pump motor	Repair or replace
		8) Damaged oil pump	Repair or replace
		9) Damaged lifting button	Repair or replace
		10) The electric lock is not unlocked or is damaged.	Repair or replace
		11) Seriously insufficient voltage in the cell.	Recharge
8	The forks cannot be lowered after lifted.	1) The internal mast is overloaded and deformed	Repair or replace
		2) The external mast is overloaded and deformed	Repair or replace
		3) Dead mast roller	Repair or adjust

		4) Mast guiding rode is curved	Repair or straighten
		5) The oil return hole is blocked	Clean
		6) The electromagnetic valve is out of control	Shoot the trouble
9	Reduced end voltage of the storage battery (after charged)	1) Damage of individual battery	Repair or replace
		2) Low level of the electrolytic solution	Add electrolytic solution
		3) Foreign matters in the electrolytic solution	Replace electrolytic solution
10	The truck shakes while traveling.	1) Driving wheel locating nuts loosen or come off.	Screw down the locating nuts.
		2) The balance wheel, driving wheel and the two front wheels are not in the same plane.	Adjust bolts on the balance wheel to make the four wheels in the same plane.

● Adjustment of the relief valve pressure

The pressure of relief valves has already been adjusted when the truck is ex-factory. Users shall not adjust the pressure at will. Otherwise it will bring danger to the truck's hydraulic system and safety. If the oil pressure is not in accordance with specified value, please ask the professional personnel to adjust according to the test methods stipulated in the JB/T3300 standards as well as the following methods:

- 1) Screw out high pressure oil tube and install pressure meter with capacity over 20Mpa at the high pressure oil outlet.
- 2) Press the lifting operation button and measure the system pressure. The specified system pressure for a truck with a rated load of 1500KG should be 16Mpa. The specified system pressure for a truck with a rated load of 2000KG should be 16.5Mpa.
- 3) If oil pressure is not in accordance with the specified value, please loosen locknuts of the overflow valves. Turn pressure screw left and right until the pressure reaches the specified value. When the screw is turned clockwise, the system pressure increases. While the screw is turned counter-clockwise, the system pressure decreases.
- 4) After the adjustment, screw down the locknuts.

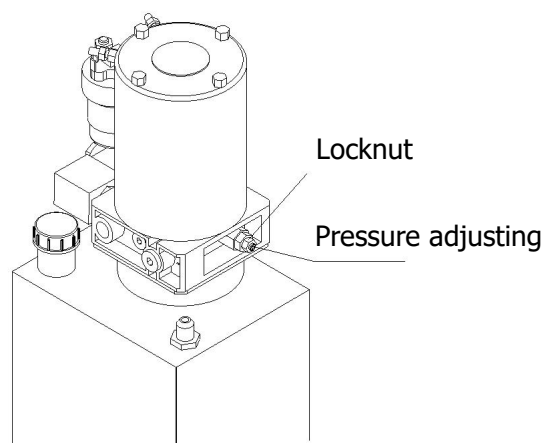

13. Common fault signal and troubleshooting

13.1 Indicator light fault diagnosis

When operating normally without any fault, the fault indicator light will stay on. If the controller detects one or more faults, the status indicator light will continuously flash the fault code until the fault is eliminated. The status indicator light can only display one fault at a time. When multiple faults occur, the status indicator light will only indicate the fault with the highest priority until this fault is eliminated.

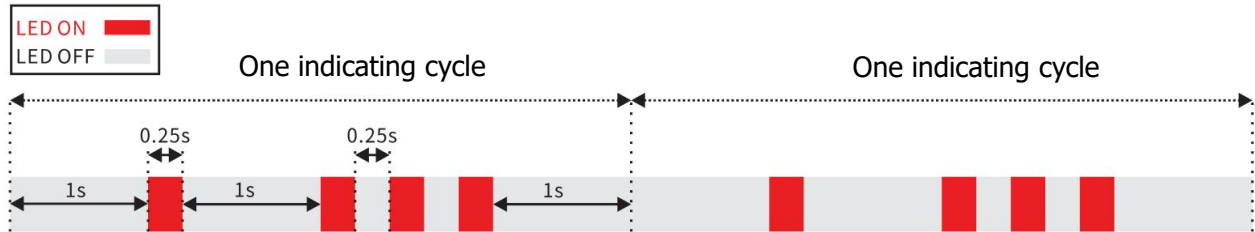

● Status indicator

Fault code	Indicator light status	Fault name
Null	Always OFF	Controller not power on, indicator light fault or severe under voltage
Null	Always ON	Works normally
1,1	☒ ☒	Over/Under temperature cut off
1,2	☒ ☒☒	The voltage at the sliding or low end of the potentiometer exceeds the range
1,3	☒ ☒☒☒	Speed limit potentiometer fault
1,4	☒ ☒☒☒☒	Lower battery voltage
1,5	☒ ☒☒☒☒☒	Lower battery voltage
2,1	☒☒ ☒	Main contactor coil drive OFF fault
2,2	☒☒ ☒☒	Wrong emergency reverse operation sequence
2,3	☒☒ ☒☒☒	Main contactor fault
2,4	☒☒ ☒☒☒☒	Main contactor coil drive ON fault
2,5	☒☒ ☒☒☒☒☒	Wrong pump operation sequence
3,1	☒☒☒ ☒	Wrong wiring
3,2	☒☒☒ ☒☒	Brake OPEN fault
3,3	☒☒☒ ☒☒☒	Pre-charge fault
3,4	☒☒☒ ☒☒☒☒	Brake OFF fault
3,5	☒☒☒ ☒☒☒☒☒	HPD fault
4,1	☒☒☒☒ ☒	Current detect fault
4,2	☒☒☒☒ ☒☒	Excessive motor voltage
4,3	☒☒☒☒ ☒☒☒	EEPROM fault
4,5	☒☒☒☒ ☒☒☒☒☒	Battery is disconnected

13.2 Debugger Diagnostics

View the real-time and historical faults of the controller by debugging the system and entering the fault diagnosis menu. The real-time fault list displays the current faults, and the historical fault list displays all faults that have occurred since the last historical fault was cleared.

● **Troubleshooting**

When the controller fails, it will handle the fault in the manner shown in the troubleshooting table to ensure system safety.

● **D2 Fault code and troubleshooting**

Fault Code Table				
Fault code	Fault	Possible causes	Fault description	Troubleshooting
1,1	Thermal Fault	<ol style="list-style-type: none"> 1) Temperature > 80°C or <-10°C; 2) The forklift is overloaded; 3) The controller does not dissipate heat effectively; 4) The electromagnetic brake is not released; 5) Temperature sensor failure; 	<p>Excessive temperature: when the temperature reaches 80°C, the current begins to decline linearly, and when the temperature reaches 105°C, the output is turned off;</p> <p>Under temperature: when the temperature is lower than -10°C, the current begins to decline linearly, and when the temperature drops to -25°C, 50% of the current is output;</p>	Fault is cleared
1,2	Throttle Fault	<ol style="list-style-type: none"> 1) The accelerator input is disconnected or short-circuited; 2) The accelerator is damaged; 3) The accelerator type is configured incorrectly; 	Slow down and stop.	Fault is cleared
1,3	Speed Pot Fault	<ol style="list-style-type: none"> 1) The input of the speed-limiting potentiometer is broken or short-circuited; 2) The speed limit potentiometer is damaged; 	The maximum speed limit is Creep Speed.	Fault is cleared
1,4	Undervoltage Fault	<ol style="list-style-type: none"> 1) The battery voltage is lower than 17V; 2) Bad wiring between the controller and the battery; 	The current limit is linearly reduced from 100% to 0% to prevent the internal relay from being disconnected due to low voltage. When the battery voltage rises to the operating limit, the controller recovers.	Fault is cleared

1,5	Overvoltage Fault	<ol style="list-style-type: none"> 1) The battery voltage is greater than 31V; 2) Plug in the charger to operate the forklift; 3) Bad wiring between the controller and the battery; 	The current limit decreases linearly from 100% to 0%. Automatically reset when the battery voltage returns to the normal range.	Fault is cleared. Restart the key switch when there is serious overvoltage (over 34V).
2,1	Main Off Fault	The internal relay drive failed to disconnect;	Does not respond to throttle input.	Fault is cleared.
2,2	EMR Sequencing Fault	Before turning on the key switch, the emergency reverse (abdomen button) switch is pressed;	Does not respond to throttle input.	The emergency reverse switch is released and the fault is cleared.
2,3	Main Fault	Internal relay failure;	Does not respond to throttle input.	The fault is cleared and the key switch is restarted.
2,4	Main On Fault	The internal relay drive failed to close;	Stop the deceleration forklift and apply electromagnetic brake. Hold the brake.	Fault is cleared
2,5	Pump SRO Fault	Before turning on the key switch, the pump switch is pressed;	If the Lift LockoutEnable parameter is set to ON, the lift lock output is turned off.	Fault is cleared
3,1	Wiring Fault	<ol style="list-style-type: none"> 1) The accelerator is not operated correctly (such as triggering HPD failure); 2) The accelerator parameter configuration is incorrect. 3) The accelerator connection is abnormal or damaged; 	You need to restart the keyswitch and clear the fault before you can respond to the throttle again.	The fault is cleared and the key switch is restarted.
3,2	Brake On Fault	<ol style="list-style-type: none"> 1) Short circuit of electromagnetic brake drive; 2) The electromagnetic brake coil is open; 	When the throttle is given as 0, the electromagnetic brake is engaged.	Fault is cleared.
3,3	Precharge Fault	<ol style="list-style-type: none"> 1) Short circuit of electromagnetic brake drive; 2) The pre-charge circuit is damaged; 3) The power MOSFET is damaged; 	The internal relay does not close, and does not respond to the throttle input, and the forklift does not run.	The fault is cleared and the key switch is restarted.

3,4	Brake Off Fault	1) The electromagnetic driver is open; 2) The electromagnetic brake coil is short-circuited;	When the throttle is given as 0, the electromagnetic brake is engaged.	Fault is cleared
3,5	HPD Fault	1) The operation sequence between accelerator and key switch or interlock input is incorrect; 2) The accelerator operation is incorrect;	Do not respond to the throttle input until the accelerator returns to neutral. If this fault lasts for 10s, the Wiring Fault will be triggered.	Fault is cleared
4,1	Current Sense Fault	1) Short circuit of motor or motor wire; 2) Controller failure;	Turn off the internal relay; do not respond to the throttle, and the motor does not run.	The fault is cleared and the key switch is restarted.
4,2	Hardware Failsafe	1) Short circuit of motor or motor wire; 2) Controller failure;	Disconnect the motor and main relay, and apply the electromagnetic brake.	The fault is cleared and the key switch is restarted.
4,3	EE CheckSum Fault	The internal parameters of the controller are faulty;	Disconnect the motor and main relay, and apply the electromagnetic brake.	Rewrite the parameters and restart the key switch.
4,5	Battery Disconnect Fault	1) The battery is not connected; 2) Bad battery wiring;	Motor short-circuit braking, electromagnetic braking.	The fault is cleared and the key switch is restarted.

● **D2SC Common fault and troubleshooting**

Fault code	Fault name	Possible causes	Fault description	Troubleshooting
1,1	Controller Overtemp Cutback	1) Temperature >80°C; 2) Vehicle load overload; and 3) Controller does not dissipate heat efficiently. 4) Electromagnetic brake not released. 5) Temperature sensor fault.	Excessive temperature: the current starts to decay linearly when the temperature reaches 80°C, and the output shuts down when the temperature reaches 105°C;	Fault is cleared
1,2	Throttle Fault	1) Accelerator input disconnected or shorted. 2) Accelerator damage 3) Accelerator type misconfiguration ;	Deceleration stops.	Fault is cleared
1,4	Undervoltage	1) Battery voltage below	The current limit drops	Fault is cleared

	Cutback	17V. 2) Poor wiring of the controller to the battery.	linearly from 100% to 0% to prevent low voltage from disconnecting the internal relay. The controller resumes when the battery voltage rises to within the operating limits.	
1,5	Overvoltage Cutback	1) Battery voltage greater than 31V. 2) Plugging in the charger to operate the vehicle. 3) Poor wiring of the controller to the battery.	Current limit decreases linearly from 100% to 0%. Automatic reset when battery voltage returns to normal range.	Fault is cleared. Severe overvoltage (over 34V) requires a key switch restart.
2,1	Main Relay DNC	Internal relay drive turn-on failure;	Does not respond to throttle input.	Fault is cleared.
2,2	EMR Sequencing Fault	The emergency reverse (belly button) switch is depressed before turning on the key or interlock switch;	Does not respond to throttle input.	The emergency reverse switch is released and the fault is cleared.
2,3	Main Driver Fault	Internal relay drive failure;	Does not respond to throttle input.	The fault is cleared and the key switch is restarted.
2,4	Main Relay Welded	Internal relays sticking.	Deceleration and stop, electromagnetic brake holds	Fault clearing.
2,5	Pump SRO Fault	Pump switch is pressed before turning on the key switch ;)	If Pump SRO Type=1 and Drive 1 Output Type is not 0, the Drive 1 output is turned off; If Pump SRO Type=2, turn off Drive Output 1 if Drive 1 Output Type is 1; turn off Drive Output 2 if Drive 2 Output Type is 1.	Fault clearing.
2,6	Creep Mode Fault	Time Limit Upright Walking Timeout Fault	Snail Mode=1, no Coast function configured, upright walking overrun reported this fault, no throttle response after fault reported.	Reset the creep speed switch;
2,7	SRO Fault	Incorrect sequence of key switch, interlock, and	Does not respond to throttle input.	Reset interlock switch, direction

		directional switch operation.		switch.
2,9	Severe Undervoltage	Battery voltage less than 14V	Turn off the electromagnetic brake, slow down the vehicle and turn off the relay in the controller.	Voltage recovery and restarts the key switch.
3,1	Wiring Fault	<ol style="list-style-type: none"> 1) Incorrect operation of the accelerator (e.g. triggering of HPD faults). 2) Accelerator parameters are not configured correctly 3) Abnormal or damaged accelerator. 	The key switch needs to be restarted and the fault cleared before the throttle can be responded to again.	The fault is cleared and the key switch is restarted.
3,2	Brake On Fault	<ol style="list-style-type: none"> 1) Electromagnetic brake drive short-circuited. 2) Electromagnetic brake coil open circuit. 	Throttle is given to 0 and the electromagnetic brakes are holding the brakes.	Fault is cleared
3,3	Precharge Fault	<ol style="list-style-type: none"> 1) Electromagnetic brake drive short-circuited. 2) Damage to the precharge circuit. 3) Damage to power MOSFETs. 	The internal relay does not close, does not respond to throttle inputs, and the vehicle does not run.	The fault is cleared and the key switch is restarted.
3,4	Brake Off Fault	<ol style="list-style-type: none"> 1) Electromagnetic brake drive open circuit. 2) Electromagnetic brake coil short-circuited. 	Throttle is given to 0 and the electromagnetic brakes are holding the brakes.	Fault is cleared
3,5	HPD Fault	<ol style="list-style-type: none"> 1) Incorrect sequence of operation between the accelerator and the key switch or interlock inputs. 2) Incorrect operation of the accelerator. 	Does not respond to throttle input until the accelerator returns to neutral, this fault lasts for 10s will trigger the Wiring Fault.	Fault is cleared
3,6	Software Fault	Software parameter mismatch	Does not respond to throttle input.	Rewrite the parameters and restart the KSI.
4,1	Current Sense Fault	<ol style="list-style-type: none"> 1) The controller parameters are configured abnormally; 2) Current sensor fault. 	Closing the internal relay does not respond to the throttle and the motor does not run.	The fault is cleared and the key switch is restarted.
4,2	Hardware Fault	<ol style="list-style-type: none"> 1) Shorted motor or shorted motor wires. 2) Controller fault. 	Disconnect the motor and main relay, electromagnetic brake holding brake.	The fault is cleared and the key switch is restarted.

4,3	Parameter Fault	Failure of internal parameters of the controller.	Disconnect the motor and main relay, electromagnetic brake holding brake.	Rewrite the parameters and then restart the key switch.
4,4	Motor Temp Hot Cutback	1) Motor blocking protection; 2) The configured Boost Current, Boost Time and Main Current and Cutback Gain under Max Current and Motor do not match.	Drops the drive current.	The limiting current is restored according to the Cutback gain recovery.
4,5	Battery Disconnect Fault	1) Battery is not connected. 2) Poor battery wiring.	Motor short-circuit braking, electromagnetic brake holding brake.	The fault is cleared and the key switch is restarted.
4,6	Motor Overtemperature	1) Motor blocking protection; 2) Configured Boost Current, Boost Time and Main Current and Cutback Gain matching under Max Current and Motor.	The motor current limit reduces the conductor Current Rating.	Limiting current is restored according to Cutback gain recovery
5,1	Low BDI	1) The battery level is below the Level 1 Low Battery setting; 2) For the controller external BMS, no CAN signal is received from the BMS.	Limit the speed according to the set primary low battery or secondary low battery.	BDI recovery and clears the fault.
5,2	Controller Overcurrent	1) Controller overcurrent; 2) The controller MOS tube is damaged. 3) The motor is short-circuited.	Does not respond to throttle input, shuts off electromagnetic brake, shuts off motor.	1. Reboot the key switch. 2. Hardware repair. 3. Clear motor short circuit fault and restart KSI.
5,3	Controller Severe Overtemp	1) Controller temperature > 105°C. 2) Overloaded. 3) Poor heat dissipation conditions. 4) Temperature sensor fault.	The drive current is reduced to 0.	The controller temperature is restored and the fault is cleared.

5,5	Parameter Change Fault	<ol style="list-style-type: none"> 1) The parameters are set incorrectly. 2) Controller EEPROM failure. 	Does not respond to throttle input.	Rewrite the parameters.
5,6	Severe Overvoltage	Battery instantaneous voltage >34V	No response to throttle input	<p>If the voltage exceeds 35.5V, the key switch needs to be reset to restore the voltage.</p> <p>If the transient voltage does not exceed 35.5V, the fault is cleared after the voltage is restored.</p>
6,1	Motor Short	<ol style="list-style-type: none"> 1) The motor is short-circuited. 2) The controller MOS tube is damaged. 	Does not respond to throttle input, vehicle decelerates, and electromagnetic brake turns off.	<ol style="list-style-type: none"> 1. Troubleshoot CAN BUS connection and restore. 2. Match termination resistors in CAN BUS circuit. 3. Set the matching BUS baud rate.
6,3	Gage PDO Timeout	Standalone CAN instrument communication timeout fault.	Instrument data is not updated.	Instrument fault is cleared
6,4	PDO Timeout	<ol style="list-style-type: none"> 1) Handle CAN BUS communication dropped. 2) CAN BUS termination resistor mismatch. 3) Inconsistent baud rate settings. 	Vehicle stops and does not respond to throttle input.	<ol style="list-style-type: none"> 1. Troubleshoot the CAN BUS connection and restore. 2. Matching of termination resistors in the CAN BUS circuit. 3. Set the matching BUS baud rate.
6,5	BMS PDO Timeout	<ol style="list-style-type: none"> 1) Stand-alone BMS communication dropout. 2) CAN BUS termination resistor mismatch. 3) Inconsistent baud rate settings. 	Power-up BMS communication failures then follow the secondary low battery speed limit.	<ol style="list-style-type: none"> 1. Troubleshoot the CAN BUS connection and restore. 2. Matching of termination

				resistors in the CAN BUS circuit. 3. Set the matching BUS baud rate.
6,6	Driver 1 On Fault	1) Driver 1 drive shorted. 2) Driver 1 coil open circuit.	Close drive 1	1. Drive 1 drive short circuit recovery and restart key switch . 2. Repair the coils on drive 1 and reboot the KSI to recover.
6,7	Driver 2 On Fault	1) Driver 2 drive short-circuited. 2) Driver 2 coil open circuit.	Close drive 2	1. Drive 2 drive short circuit recovery and restart key switch. 2. Repair the coil on drive 2 and reboot the KSI to recover.
7,1	Driver 1 Off Fault	1) Driver 1 drive open circuit; 2) Drive 1 coil shorted.	Close drive 1	1. Drive 1 drive open circuit recovery and restart key switch. 2. Repair the coils on drive 1 and reboot the KSI to recover.
7,2	Driver 2 Off Fault	1) Driver 2 drive open circuit; 2) Drive 2 coil shorted.	Close drive 2	1. Drive 2 drive open circuit recovery and restart key switch. 2. Repair the coil on drive 2 and reboot the KSI to recover.

14. Lists of accessories, spare parts and wearing parts

No.	Name	Application	specification	Quantity	Remarks
1	E-lock key	E-lock		2	
2	Fuse	Electric parts	50A	1	
3	Fuse	Electric parts	125A	1	
4	Seal ring	Cylinder	UHS45	1	
5	O ring	Cylinder	50X3.55	1	
7	Bonded washer	Cylinder inlet	D14	1	
8	Dust ring	Cylinder	DH40	1	
9	Seal ring	Cylinder	UHS40	1	

15. Structure diagram (explosion diagram) and principle diagram of the major parts

- Hydraulic schematic diagram

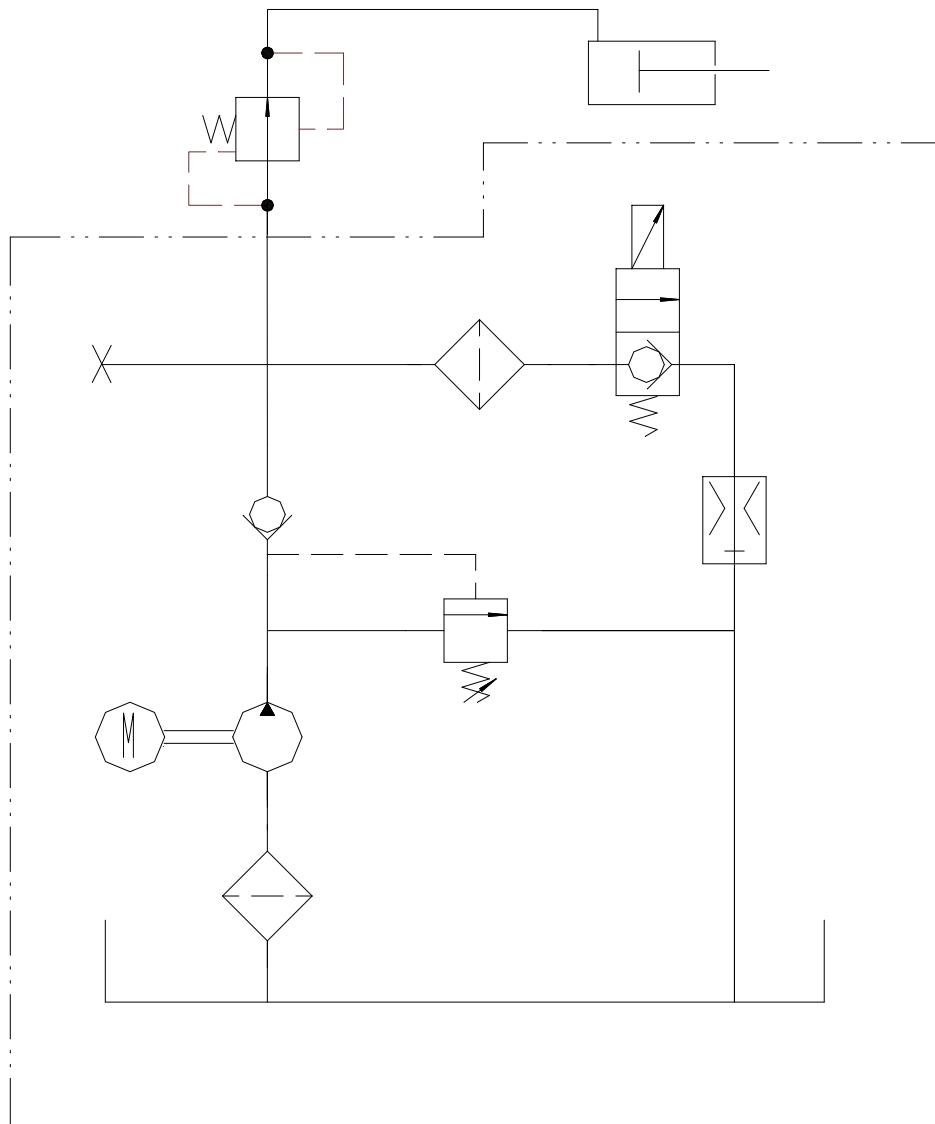

● Schematic Diagram

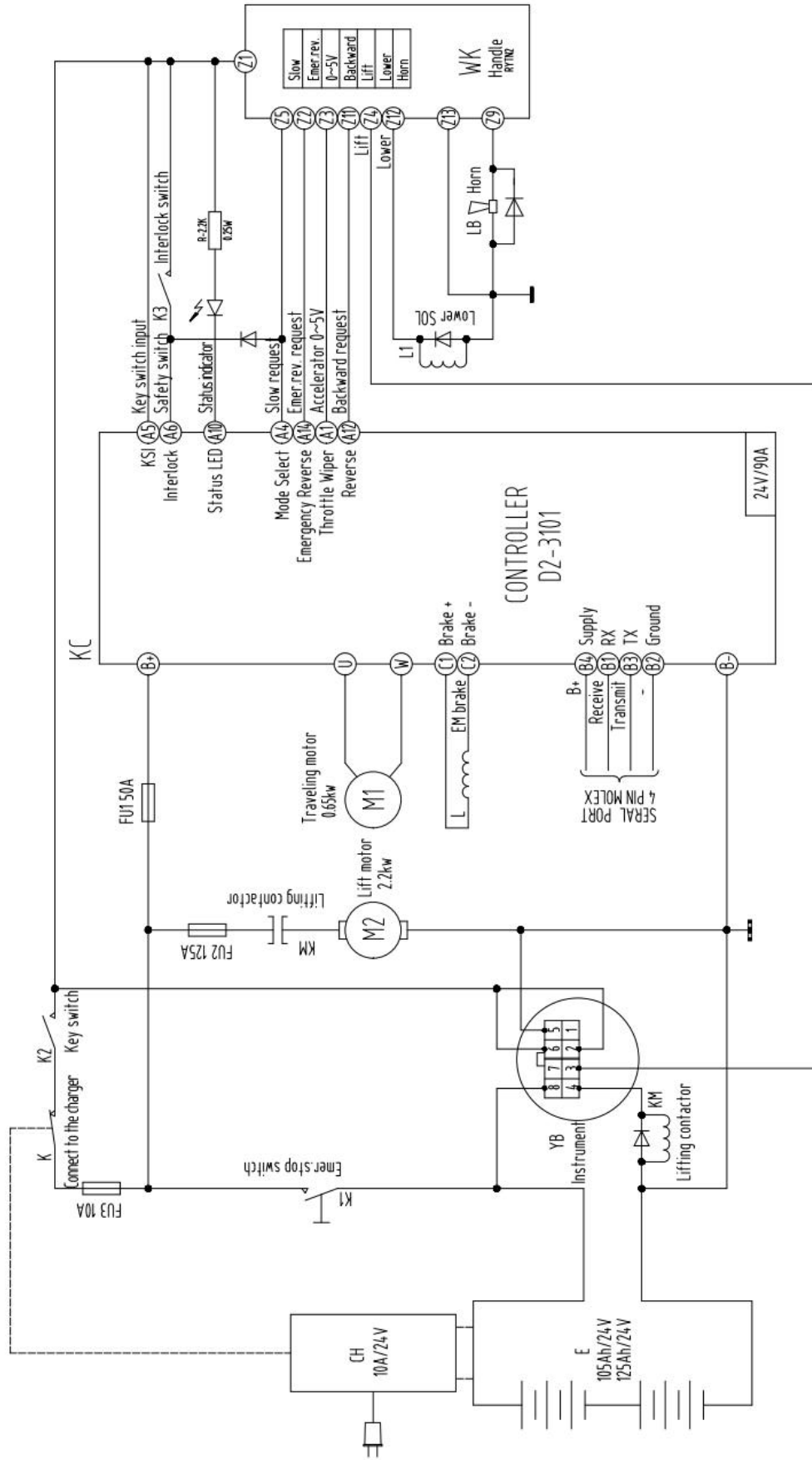

D2 electric schematic diagram (Lead-acid battery)

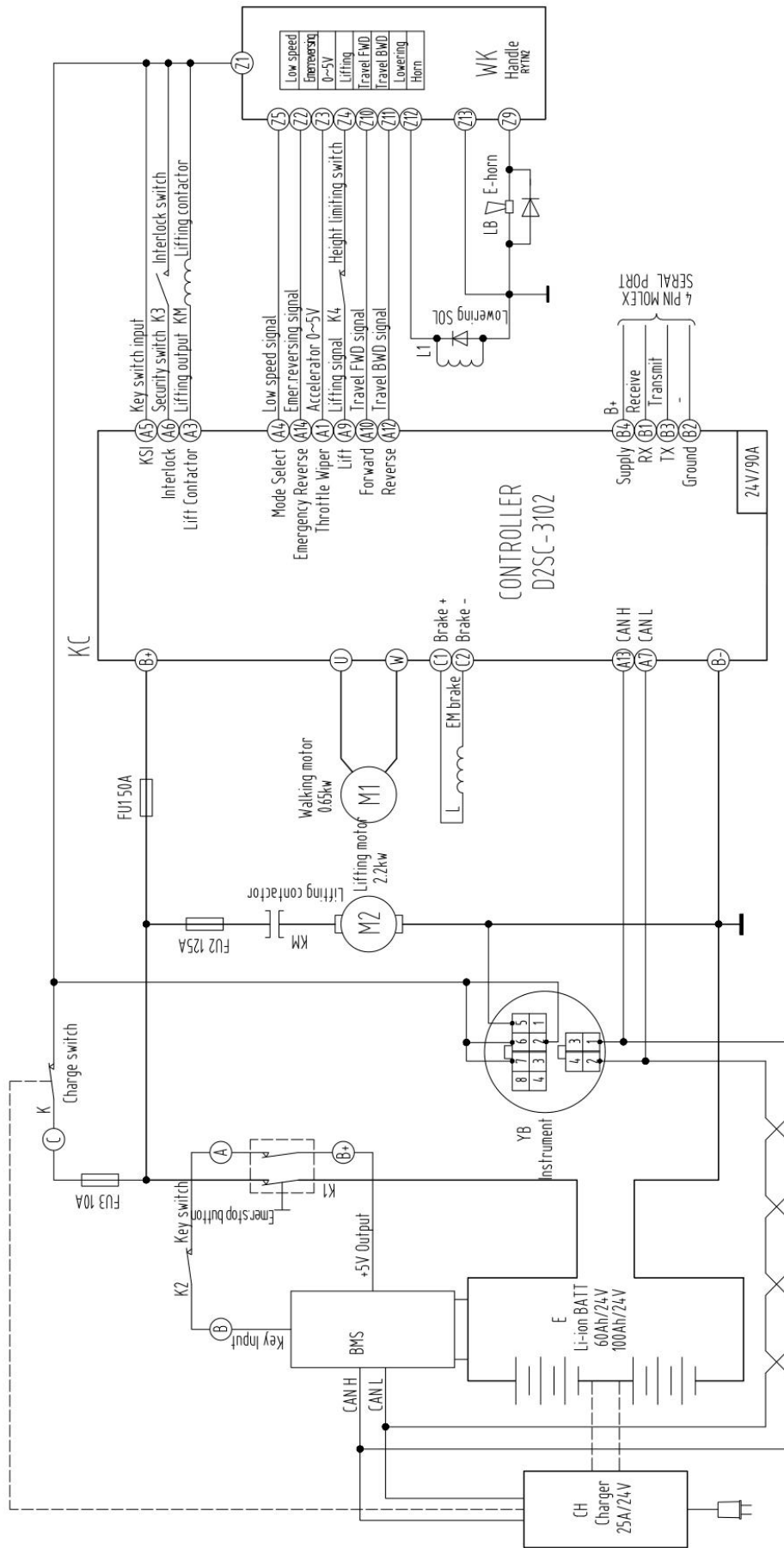

D2S electric schematic diagram (Lithium battery)

16. Packing list

Packing list of CTD15R-E/N electric pallet stacker

Consignee:

Ex-work No.:

Contract No.:

Ex-work Date:

No.	Name	Quantity	Net weight (kg)	Dimension (L×W×H)	Remarks
1	CTD15R-E/N electric pallet stacker	1			A complete set.
2	Accessory box	1			Technical documents, accessories and spare parts.

Note: 1. following documents are in the file bag:

- | | |
|---|----------|
| ①Operation manual of CTD15R-E/N Electric Pallet Stacker | 1 volume |
| ②Packing list | 1 copy |
| ③Qualification certificate | 1 copy |

2. Accessories and spare parts

No.	Name	Application	specification	Quantity	Remarks
1	E-lock key	E-lock		2	
2	Fuse	Electric parts	50A	1	
3	Fuse	Electric parts	125A	1	
4	Seal ring	Cylinder	UHS50-60-6	1	
5	O ring	Cylinder	60X3.55	1	
6	Bonded washer	Cylinder inlet	D14	1	
7	Dust ring	Cylinder	DHS50-58-5/6.5	1	
8	Seal ring	Cylinder	ODI70-50-12	1	

Consigner:

